



# PROMETHEUS

## Thermal Imaging Monocular



## OPERATION AND MAINTENANCE MANUAL

**Important Export Restrictions!** Commodities, products, technologies and services of this manual are controlled by the U.S. Department of State Office of Defense Trade Controls, in accordance with International Traffic in Arms (ITAR), Title 22, Code of Federal Regulations Part 120-130 and/or by the Export Administration Regulations (EAR) of U.S. Department of Commerce. At any time when a license or a written approval of the U.S. Government is applicable to it, it is illegal and strictly forbidden to export, intend to export, transfer in any other manner whatsoever, sell any hardware or technical data, provide any associated service to any non-U.S. resident, beyond or within the United States territory, until the valid license or written approval has been issued by the Departments of the U.S. Government having jurisdiction. Additionally U.S. law prohibits the sale, transfer, or export of items to certain restricted parties, destinations, and embargoed countries, as identified on lists maintained by the U.S. Department of State, the U.S. Department of Commerce, and the U.S. Department of Treasury. It is the responsibility of the Customer to be aware of these lists. The sale, transfer, transportation, or shipment outside of the U.S. of any product prohibited or restricted for export without complying with U.S. export control laws and regulations, including proper export licensing, documentation or authorization, is unlawful and may result in civil and/or criminal penalties and/or constitute a federal crime. Diversion contrary to U.S. law is strictly prohibited.

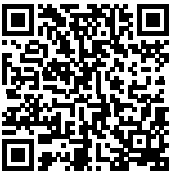

## SAFETY SUMMARY

Before operating this product, carefully study this Operation and Maintenance Manual.

The Armasight Prometheus Thermal Imaging Monocular is a precision electro-optical instrument and requires careful handling. To avoid physical danger to the user and damage to the equipment, follow all WARNINGS, CAUTIONS and NOTES.

Below are definitions of the alerts that will appear throughout this Manual:

**WARNING** – Identifies a clear danger to the person operating the equipment.

**CAUTION** – Identifies risk of damage to the equipment.

**NOTE** – Highlights essential procedures, conditions, statements, and important instructional information for the user.

The information provided in this manual is for familiarization purposes only. The contents may undergo further changes with no commitment by Armasight® to notify customers of any updates.

Armasight® assumes no responsibility for any misprints or other errors that this manual may contain.

© Armasight Inc. 2015

**WARNING:**

**This product contains natural rubber latex, which may cause allergic reactions!** The FDA has reported an increase in the number of deaths associated with sensitivity to natural latex proteins. If you are allergic to latex, learn which products contain it and strictly avoid exposure to those products.

**CAUTION:**

- Do not dismantle the equipment.
- Keep the equipment clean. Protect it from moisture, dramatic temperature drops, and electrical shocks.
- DO NOT force the equipment controls past their stopping points.
- DO NOT leave the equipment activated during breaks in operation.
- DO NOT store the equipment with the batteries installed.
- Thoroughly clean and dry each item before placing them into the storage case.

**CAUTION:**

To prevent thermal damage to the equipment, never point it, either on or off, directly at the sun or any other source of high intensity light that the unprotected human eye cannot tolerate (such as a welding arc). To prevent inadvertent exposure to these types of sources, never leave the equipment with the objective lens cap off.

**NOTES:**

- To avoid losing unsaved data, DO NOT remove the batteries or disconnect the external power source while the Prometheus is on.
- Inadvertent sun damage is not considered a defect in material or workmanship, and is therefore not covered in the product warranty.

# LIST OF CONTENTS

TITLE	PAGE
<b>Safety Summary</b>	2
<b>List of Contents</b>	4
<b>List of Figures</b>	5
<b>List of Tables</b>	6
<b>How to Use This Manual</b>	6
<b>1. INTRODUCTION</b>	<b>7</b>
<b>1.1 General Information</b>	7
1.1.1 Type of Manual	7
1.1.2 Model Number and Equipment Name	7
1.1.3 Purpose of Equipment	8
1.1.4 Reporting Equipment Improvement Recommendations	8
<b>1.2 Warranty Information and Registration</b>	8
1.2.1 Warranty Information	8
1.2.2 Limitation of Liability	9
1.2.3 Product Warranty Registration	9
1.2.4 Obtaining Warranty Service	9
<b>1.3 List of Abbreviations</b>	10
<b>2. DESCRIPTION AND DATA</b>	<b>11</b>
<b>2.1 System Description</b>	11
<b>2.2 Specifications</b>	13
<b>2.3 Standard Components</b>	15
<b>2.4 Optional Equipment</b>	16
<b>2.5 Key Features</b>	17
<b>3. OPERATING INSTRUCTIONS</b>	<b>18</b>
<b>3.1 Installation and Mounting</b>	18
3.1.1 Battery Installation	18
3.1.2 Mounting a Platform Ring	18
3.1.3 Fastening an Advanced Wireless Remote Control	19
3.1.4 Installing Additional Equipment	19
3.1.5 Connecting an Additional Equipment	19
3.1.6 Installing the Prometheus on a Tripod	20
<b>3.2 Controls and Display Indications</b>	20
3.2.1 Controls	20
3.2.2 Main Menu	22
<b>3.3 Operating Procedures</b>	26
3.3.1 Operating	26
3.3.2 Prometheus Shut-Down	28

<b>4. PREVENTIVE MAINTENANCE AND TROUBLESHOOTING</b>	<b>29</b>
<b>4.1 Preventive Maintenance Checks and Services</b>	29
4.1.1 Preventive Maintenance Checks and Services (PMCS)	29
<b>4.2 Operator Troubleshooting</b>	31
<b>4.3 Maintenance</b>	32
4.3.1 General	32
4.3.2 Cleaning Procedures	32
4.3.3 Battery Removal and Replacement	32
<b>4.4 Return Instructions</b>	<b>33</b>
<b>APPENDIX</b>	<b>34</b>
<b>A Product Warranty Registration Card</b>	34
<b>B List of Spare Parts</b>	35

## LIST OF FIGURES

FIGURE	TITLE	PAGE
2-1	Prometheus Thermal Imaging Monoculars Appearance	11
2-2	System Description	12
2-3	Standard Components	15
2-4	Optional Equipment	16
3-1	Battery Installation	18
3-2	Platform Ring	19
3-3	Advanced Wireless Remote Control	19
3-4	Armasight Digital Recorder DT Installation	20
3-5	Video Cable	20
3-6	Controls	21
3-7	Button Control Panel	22
3-8	Main Menu	23
3-9	Palette Menu	23
3-10	Palette Menu. Continued	24
3-11	Enhancement Menu	24
3-12	Digital Contrast Correction	24
3-13	Sharpness Correction	25
3-14	Smart Scene Optimization	25
3-15	Gain Correction	25
3-16	Settings Menu	26
3-17	Setting Buttons	27
4-1	Advanced Wireless Remote Control Battery Installation	32
B-1	Prometheus Spare Parts List	35

## LIST OF TABLES

TABLE	TITLE	PAGE
2-1	System Description	13
2-2	System Data	13
2-3	Optical Data	13
2-4	Electrical Data	14
2-5	Mechanical Data	14
2-6	Environmental Data	14
2-7	Advanced Wireless Remote Control (AWREC) Data	14
2-8	Standard Components	15
2-9	Optional Equipment	16
3-1	Controls and Indicators	21
3-2	Button Controls	22
4-1	Preventive Maintenance Checks and Services	29
4-2	Operator Troubleshooting	31
B-1	Prometheus Spare Parts List	35

## HOW TO USE THIS MANUAL

### USAGE

You must familiarize yourself with the entire manual before operating the equipment. Read the entire maintenance checklist before performing maintenance. Follow all **WARNINGS**, **CAUTIONS**, and **NOTES**.

### MANUAL OVERVIEW

The Manual contains sections on operating and maintaining the Prometheus Thermal Imaging Monocular.

Throughout this Manual, the Prometheus Thermal Imaging Monocular will be referred to as the Prometheus, "the device," or "the equipment."

The Product Warranty Registration Card is in Appendix A.

A List of Spare Parts is in Appendix B.

# INTRODUCTION

## 1.1 GENERAL INFORMATION

### 1.1.1 TYPE OF MANUAL

Operation and Maintenance (including a List of Spare Parts).

### 1.1.2 MODEL NUMBER AND EQUIPMENT NAME

The Prometheus Thermal Imaging Monocular is available in the following versions that are structurally different in terms of thermal imaging cameras and objective lenses:

**Prometheus 336 2-8x25 (9 Hz)**, FLIR Tau 2 - 336x256 (17 $\mu$ m) 9Hz Core, 25mm Lens

**Prometheus 336 2-8x25 (30 Hz)**, FLIR Tau 2 - 336x256 (17 $\mu$ m) 30Hz Core, 25mm Lens

**Prometheus 336 2-8x25 (60 Hz)**, FLIR Tau 2 - 336x256 (17 $\mu$ m) 60Hz Core, 25mm Lens

**Prometheus 336 3-12x42 (9 Hz)**, FLIR Tau 2 - 336x256 (17 $\mu$ m) 9Hz Core, 42mm Lens

**Prometheus 336 3-12x42 (30 Hz)**, FLIR Tau 2 - 336x256 (17 $\mu$ m) 30Hz Core, 42mm Lens

**Prometheus 336 3-12x42 (60 Hz)**, FLIR Tau 2 - 336x256 (17 $\mu$ m) 60Hz Core, 42mm Lens

**Prometheus 640 1-8x25 (30 Hz)**, FLIR Tau 2 - 640x512 (17 $\mu$ m) 30Hz Core, 25mm Lens

**Prometheus 640 2-16x42 (30 Hz)**, FLIR Tau 2 - 640x512 (17 $\mu$ m) 30Hz Core, 42mm Lens

**Prometheus 640 2-16x42 (60 Hz)**, FLIR Tau 2 - 640x512 (17 $\mu$ m) 60Hz Core, 42mm Lens

### 1.1.3 PURPOSE OF EQUIPMENT

Armasight Prometheus is the latest and most technologically-advanced family of thermal imaging monoculars for the sporting, law enforcement, and military markets. The Prometheus product line is based on the latest FLIR Tau 2 VOx microbolometer core, and is composed of different models – each optimized for performance, price, and state-of-the-art technology that is suitable for a variety of uses and missions.

The Prometheus is a solid state, uncooled, long-wave infrared, magnified, dedicated handheld thermal imager intended for day and nighttime missions.

The 24/7 mission capability is only one of the strengths of the Prometheus line. The thermal imaging technology also allows you to detect targets by cutting through snow, dust, smoke, fog, haze, and other atmospheric obscurants. Unlike the use of laser targeting or near-infrared illumination to augment night vision equipment, the Prometheus thermal imager is extremely difficult to detect with other devices, as it emits no visible light or RF energy.

The Prometheus is available in different versions, with optical magnifications ranging from 1x to 3x. Prometheus series also provides up to 8x digital zoom for models based on 640x512 cores and up to 4x digital zoom for models based on a 336x256 core.

The Prometheus is powered by two CR123A (2x3V) batteries. The Extended Battery Pack or 6VDC/ 600mA power source can also be used to power the Prometheus.

The Prometheus can be controlled by a wireless remote control.

The Prometheus is equipped with a standard NTSC/PAL video input/output function that makes it possible to connect to an external video display or monitor, or to record thermal images for field documentation or training purposes. It also allows the transmission of data from one remote display to that of the Prometheus.

The Prometheus can be used in conjunction with other Armasight equipment such as the Digital Video Recorder or Extended Battery Pack that can be mounted onto the Prometheus' Picatinny/ Weaver rail or detachable platform ring.

Extremely reliable and versatile, the Prometheus is a highly useful thermal imaging system.

## 1.1.4 REPORTING EQUIPMENT IMPROVEMENT RECOMMENDATIONS

User recommendations for improvements to the device are encouraged.

Mail your comments to:

Armasight Inc.

815 Dubuque Avenue,

South San Francisco, CA 94080

USA

Or, send an email to [info@armasight.com](mailto:info@armasight.com).

## 1.2 WARRANTY INFORMATION AND REGISTRATION

### 1.2.1 WARRANTY INFORMATION

This product is guaranteed to be free from manufacturing defects in material and workmanship under normal use for a period of three (3) years from the date of purchase. This warranty does not cover the battery or damage caused by leaking batteries. Nor does it protect against damage due to loss, misuse or mishandling. The uncooled thermal camera sensor is warrantied for a period of ten (10) years from the date of purchase.

In the event a defect that is covered by the warranty occurs during the 3 year period stated above, Armasight, at its option, will either repair or replace the product, and such action on the part of Armasight shall be the full extent of Armasight's liability, and the Customer's sole and exclusive remedy. This warranty does not cover a product (a) used in other than its normal and customary manner; (b) subjected to misuse; (c) subjected to alterations, modifications or repairs by the Customer or by any party other than Armasight without prior written consent of Armasight; (d) special order or "close-out" merchandise or merchandise sold "as-is" by either Armasight or the Armasight dealer; or (e) merchandise that has been discontinued by the manufacturer and either parts or replacement units are not available due to reasons beyond the control of Armasight. Armasight shall not be responsible for any defects or damage that in, Armasight's opinion, is a result from the mishandling, abuse, misuse, improper storage or improper operation, including use in conjunction with equipment which is electrically or mechanically incompatible with or of inferior quality to the product, as well as failure to maintain the environmental conditions specified by the manufacturer.

This warranty is extended only to the original purchaser. Any breach of this warranty shall be waived unless the customer notifies Armasight at the address noted below within the applicable warranty period.

The customer understands and agrees that except for the foregoing warranty, no other warranties written or oral, statutory, expressed or implied, including any implied warranty of merchantability or fitness for a particular purpose, shall apply to the product. All such implied warranties are hereby and expressly disclaimed.



## **1.2.2 LIMITATION OF LIABILITY**

Armasight will not be liable for any claims, actions, suits, proceedings, costs, expenses, damages or liabilities arising out of the use of this product. Operation and use of the product are the sole responsibility of the Customer. Armasight's sole undertaking is limited to providing the products and services outlined herein in accordance with the terms and conditions of this Agreement. The provision of products sold and services performed by Armasight to the Customer shall not be interpreted, construed, or regarded, either expressly or implied, as being for the benefit of or creating any obligation toward any third party or legal entity outside Armasight and the Customer. Armasight's obligations under this Agreement extend solely to the Customer.

Armasight's liability hereunder for damages, regardless of the form or action, shall not exceed the fees or other charges paid to Armasight by the customer or customer's dealer. Armasight shall not, in any event, be liable for special, indirect, incidental, or consequential damages, including, but not limited to, lost income, lost revenue, or lost profit, whether such damages were foreseeable or not at the time of purchase, and whether or not such damages arise out of a breach of warranty, a breach of agreement, negligence, strict liability or any other theory of liability.

## **1.2.3 PRODUCT WARRANTY REGISTRATION**

In order to validate the warranty on your product, Armasight must receive a completed Product Warranty Registration Card for each unit, or the Customer can complete a warranty registration on our website at [www.armsight.com](http://www.armsight.com). Please complete the included form (Appendix B) and immediately mail it to our Service Center:

Armasight Inc.  
815 Dubuque Avenue  
South San Francisco, CA 94080  
USA

## **1.2.4 OBTAINING WARRANTY SERVICE**

To obtain warranty service on your unit, the End-User must notify the Armasight's service department in order to receive a Return Merchandise Authorization number (RMA#). The customer can do this by sending an email to [service@armsight.com](mailto:service@armsight.com).

When returning any product, please take or send the product, postage paid, with a copy of your sales receipt, to our service center, Armasight Inc. at the address noted above. All merchandise must be fully insured with the correct postage; Armasight will not be responsible for improper postage or missing or damaged merchandise during shipment.

When sending merchandise back, please write the RMA# clearly on the outside of the shipping box. Please include a letter that indicates your RMA#, Name, Return Address, reason for service return, Contact information (such as a valid telephone number and/or e-mail address), as well as proof of your purchases that will help us to establish the valid start date of the warranty. Product merchandise returns that do not have an RMA listed may be refused or be subject to a significant delay in processing.

Estimated Warranty service time is 10-20 business days. The End-User/Customer is responsible for postage to Armasight for any warranty service. Armasight will cover return postage/shipping to continental USA End-Users/Customers after warranty repair only if product is covered by the aforementioned warranty. Armasight will return the product after warranty service via domestic ground service and/or domestic mail. The postage and shipping fees for any other requested, required or international shipping methods will be the responsibility of the End-User/Customer.

## 1.3 LIST OF ABBREVIATIONS

$\mu\text{m}$	micrometer
AWREC	Advanced Wireless Remote Control
C	Celsius (Centigrade)
CCW	counterclockwise
CW	clockwise
F	Fahrenheit
FL	Focal Length
g	gram
H	Height
hr	hour
in	inch
inf.	infinity
kg	kilogram
L	Length
lbs	pounds
m	meter
mA	milliampere
min	minute
mm	millimeter
NO.	Number
NTSC	National Television Standards Committee
NUC	Non Uniformity Correction
OEM	Original Equipment Manufacturer
oz	ounce
PAL	Phase Alternating Line
PMCS	Preventive Maintenance Checks and Services
RMA#	Return Merchandise Authorization number
sec	second
SEQ	sequence
SR	Service Representative
UCMNUC/ FFC	User-Controlled Manual Non-Uniformity Correction/ Flat-Field Correction
V	Volt
W	Width

## DESCRIPTION AND DATA

### 2.1 SYSTEM DESCRIPTION

The Prometheus consists of next primary parts: a body, a lens assembly and an eyepiece assembly. Figure 2-1 represents two versions of the equipment: with 25mm and 42mm focal length objective lens.

The Prometheus is a thermosensitive device. It senses the differences in heat emitted by objects in its field of view, and converts the received temperature pattern into a viewable image that represents the scene in contrasting black & white or color patterns, depending on the user's selected image palette.

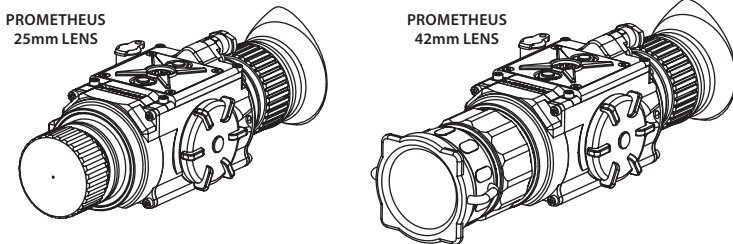

**FIGURE 2-1. PROMETHEUS THERMAL IMAGING MONOCULARS APPEARANCE**

**NOTE:**

It is important that the Prometheus sensor receive sufficient thermal contrast between the target and background area, or between the different parts of a target. For example, the vast temperature contrast between the snow and any heat target (such as an animal) makes it very easy to distinguish the target.

The main optical-electronic components of the Prometheus include: an objective Germanium thermal lens, eyepiece, a thermal-imaging camera, a display, a control card, and a button control panel.

The Prometheus is equipped with manual eyepiece and objective lens focusing.

To accommodate individual user needs, the Prometheus has a variety of digitally controlled options such as:

- Display Brightness
- Digital Zoom
- Palette Color Selection
- User-Controlled Manual Non-Uniformity Correction/ Flat-Field Correction (UCMNUC/ FFC)
- Imaging Enhancements
- Custom Settings

All Prometheus devices are based on FLIR Tau 2.7.2 or later cameras that allow for improvements in overall image quality in a wide range of dynamic thermal environments. The Prometheus has employed special user-adjustable imaging tools that include:

- **Active Contrast Enhancement (ACE)** – a digital “Contrast” correction that allows for smart scene optimization based on dynamic adjustments, where a variety of contrast levels occur depending on relative scene temperature.
- **Second Generation Digital Detail Enhancement (DDE)** – a “Sharpness” correction that digitally enhances the picture, significantly sharpens edges, and further reduces image noise.
- **Smart Scene Optimization (SSO)** – a fine-tuning computational correction that significantly improves overall visual acuity for targets that have thermal signatures similar to the surrounding background.
- **Automatic Gain Control (AGC)** – a “Gain” correction that used to automatically adjust the gain to an appropriate range, the weaker the image signal, the stronger the gain.
- **User-Controlled Manual Non-Uniformity Correction/ Flat-Field Correction (UCMNUC/ FFC).** There is a mechanical shutter between the camera sensor and the lens. This shutter is used to perform a non-uniformity correction (NUC), also known as flat-field correction (FFC). During FFC, the shutter presents a uniform temperature source to each detector element in the array. While imaging the flat-field source, the camera updates the offset correction coefficients, resulting in a more uniform image after the process is complete. All Prometheus models allow for user to manually trigger or interrupt scheduled UCMNUC/ FFC function.
- **Silent Shutterless NUC™ (SSN)** – In addition to User-Controlled Manual NUC/ FFC, all Prometheus models employ a digital, supplemental, non-mechanical flat-field correction that extends periods between mechanical shutter events and further reduces image noise. SSN is an always ON enhancement.

Information on the current operating state (battery status, active function in the display etc.) is continuously displayed, making field operation of the Prometheus simple and convenient.

Manufactured for exceptional durability, the Prometheus has a lightweight and robust aluminum body. A side Picatinny/ Weaver rail allows for the installation of an optional Armasight Digital Video Recorder, extended battery pack, or other equipment.

An optional detachable Platform Ring makes it possible to mount additional equipment to the device. A standard NTSC/PAL video input/ output connector enables an external video display (monitor/ TV) or video recorder to be connected to the Prometheus. An external 6VDC/600mA power source can also be connected to the Prometheus.

The Prometheus is powered by two CR123A (2×3V) batteries.

Figure 2-2 shows the Prometheus with a 42mm lens. The ITEM NO. column of Table 2-1 indicates the number used to identify items in Figure 2-2.

**NOTE:**

Here and below, the example used is the Prometheus with a 42mm lens.

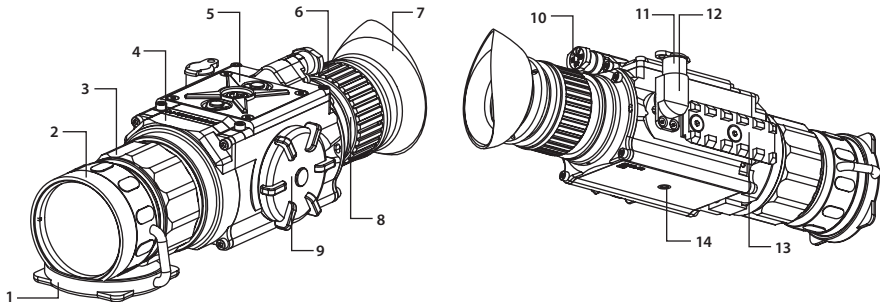

**FIGURE 2-2. PROMETHEUS THERMAL IMAGING MONOCULAR. SYSTEM DESCRIPTION**

**TABLE 2-1. SYSTEM DESCRIPTION**

ITEM	DESCRIPTION	ITEM	DESCRIPTION
1	Objective Lens Cap	8	Eyepiece
2	Objective Lens	9	Battery Cap
3	Objective Focus Ring	10	Turn-Pull Switch
4	Body	11	Connector Cap
5	Button Control Panel	12	Connector
6	Eyepiece Focus Ring	13	Side Picatinny/ Weaver Rail
7	Eyecup	14	Tripod Socket

## 2.2 SPECIFICATIONS

**TABLE 2-2. SYSTEM DATA**

ITEM	PROMETHEUS 336 2-8x25	PROMETHEUS 336 3-12x42	PROMETHEUS 640 1-8x25	PROMETHEUS 640 2-16x42
Optical Magnification (NTSC/ PAL)	1.6x	2.8x / 3.4x	1x	1.5x / 1.8x
Objective Lens Type	Germanium			
Focal Plane Array	FLIR Tau 2			
Frame Rate	9 Hz, or 30 Hz, or 60 Hz		30Hz	30 Hz or 60 Hz
Pixel Array Format	336x256		640x512	
Pixel Size	17 μm			
Display Type	LED VGA	OLED SVGA	LED VGA	OLED SVGA
Pixel Display Format	640x480	800x600	640x480	800x600
Display Brightness	Discretely Adjustable to 8 Levels			
Turn-on Time, max	3 sec			
Digital Zoom	1x, 2x, 4x		1x, 2x, 4x, 8x	
Temperature Imaging Modes (Image Palettes)	White Hot, Black Hot, Fusion, Rainbow, Globow, Ironbow1, Ironbow2, Sepia, Color1, Color2, Ice-Fire, Rain, and OEM			
User-adjustable Image Enhancement Tools	<ul style="list-style-type: none"> <li>•Active Contrast Enhancement (ACE) - "CONTRAST"</li> <li>•Second Generation Digital Detail Enhancement (DDE) - "SHARPNESS"</li> <li>•Smart Scene Optimization (SSO) - "SMART SCENE"                             <ul style="list-style-type: none"> <li>•Automatic Gain Control - "GAIN"</li> </ul> </li> <li>•User-Controlled Manual Non-Uniformity Correction/ Flat-Field Correction (UCMNUC/ FFC)                             <ul style="list-style-type: none"> <li>•Silent Shutterless NUC™ (SSN)</li> </ul> </li> </ul>			
Analog Video Input/ Output Format (resolution)	PAL (768x574 pixels)* / NTSC (640x480 pixels)			

\*Default setting (may be altered at the customer's request).

**TABLE 2-3. OPTICAL DATA**

ITEM	PROMETHEUS 336 2-8x25	PROMETHEUS 336 3-12x42	PROMETHEUS 640 1-8x25	PROMETHEUS 640 2-16x42
Field of View - ang. X (degrees)	13	7.8	24	14.8
View - ang. Y (degrees)	10	5.9	20	11.8
Objective Focal Length	25mm	42mm	25mm	42mm
Objective F-number	1:1	1:1	1:1	1:1

**TABLE 2-3. CONTINUED**

ITEM	PROMETHEUS 336 2-8x25	PROMETHEUS 336 3-12x42	PROMETHEUS 640 1-8x25	PROMETHEUS 640 2-16x42
Exit Pupil Diameter	14 mm			
Eye Relief	25 mm			
Focus Method	-	Manual	-	Manual
Focusing Range	20m to inf.	5m to inf.	20m to inf.	5m to inf.
Diopter Adjustment	Manual			
Diopter Adjustment Range	±5 diopter			

**TABLE 2-4. ELECTRICAL DATA**

ITEM	DATA
Battery	Two CR123A 3V Lithium batteries or CR123 type rechargeable batteries with voltage from 3.0V to 3.7V (2)*
Current Consumption, maximum	320 mA
Battery Life at 20°C (68 °F)	up to 4 hr (optional up to 12 hrs)
Extended Battery Pack	Two 18650 rechargeable batteries (3.7V), four CR123 rechargeable batteries with voltage 3.7V max, or four standard CR123A 3V Lithium batteries (operational time up to 8 hr)
External Power Supply	6 VDC/ 600mA

\* Rechargeable batteries with voltage 3.0V-3.7V can be used only in devices with serial number starting from 140885

**TABLE 2-5. MECHANICAL DATA**

ITEM	PROMETHEUS 336 2-8x25 PROMETHEUS 640 1-8x25	PROMETHEUS 336 3-12x42 PROMETHEUS 640 2-16x42
Overall Dimensions	180x68x62 mm (7.1x2.7x2.4 in)	194x68x62 mm (7.6x2.7x2.4 in)
Weight (w/o Batteries)	0.48 kg (1.1 lbs)	0.55 kg (1.2 lbs)

**TABLE 2-6. ENVIRONMENTAL DATA**

ITEM	DATA
Operating Temperature	-40 to +50°C (-40 to +122°F)
Storage Temperature	-50 to +70°C (-58 to +158°F)
Recoil Resistance	700 g
Environmental Rating	Water and Fog-Resistant

**TABLE 2-7. ADVANCED WIRELESS REMOTE CONTROL (AWREC) DATA**

ITEM	DATA
Type	Wireless Remote Control
Working Range	Up to 0.5m
Battery	Single CR2032 Lithium battery (3V)
Battery Life at 20 °C (68 °F)	Approx. 10,000 clicks
Overall Dimensions	48x39x18 mm (1.9"x1.5"x0.7")
Weight (with Battery)	25 g (0.9 oz)
Operating Temperature	-30 to +50°C (-22 to 122°F)
Storage Temperature	-50 to +70°C (-58 to 158°F)
Environmental Rating	Water and Fog-Resistant

## 2.3 STANDARD COMPONENTS

The Prometheus standard components are shown in Figure 2-3 and listed in Table 2-8. The ITEM NO. column indicates the number used to identify items in Figure 2-3.

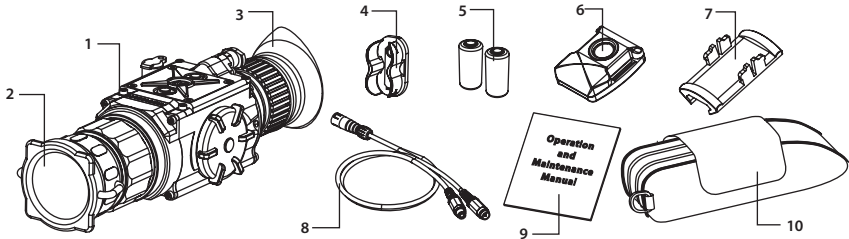

**FIGURE 2-3. STANDARD COMPONENTS**

**TABLE 2-8. STANDARD COMPONENTS**

ITEM NO.	DESCRIPTION	QUANTITY
1	<b>Armasight Prometheus Thermal Imaging Monocular</b> A thermal imaging device.	1
2	<b>Objective Lens Cap</b> Securely protects the objective lens from dirt and mechanical damage and provides thermal protection of the Prometheus. Comes attached to the objective lens.	1
3	<b>Eyecup</b> A specially designed latex eyecup that reduces the amount of light that escapes from the eyepiece and prevents illumination of the user's face, minimizing the risk of detection. Prevents ambient light from entering the equipment. Allows for correct and comfortable positioning. Comes attached to the eyepiece.	1
4	<b>Battery Cassette</b> Intended for the installation of two CR123 batteries in the battery compartment. The Prometheus comes with two battery cassettes (includes one installed in the battery compartment and one spare cassette).	2
5	<b>CR123A Lithium Battery</b> Two CR123A batteries are used to power the Prometheus.	2
6	<b>Advanced Wireless Remote Control (AWREC)</b> Allows the user to operate the Prometheus in short-time activation mode. Ensures quick and silent activation/deactivation of the equipment. Comes with CR2032 (3V) battery installed.	1
7	<b>Picatinny Adapter for Advanced Wireless Remote Control</b> Allows the advanced wireless remote control to be installed on a Picatinny/Weaver rail.	1
8	<b>Video Cable</b> A cable used to connect the analog video input/output of the Prometheus to external display devices (monitor/ TV) or power sources. Supported input and output video formats include PAL and NTSC.	1
9	<b>Operation and Maintenance Manual</b> Provides safety information, equipment description, mounting procedures, operating instructions, and preventive maintenance checks and services.	1
10	<b>Carrying Case</b> A textile bag used for the transportation and storage of the Prometheus and its accessories.	1

## 2.4 OPTIONAL EQUIPMENT

Optional items are shown in Figure 2-4 and listed in Table 2-9.

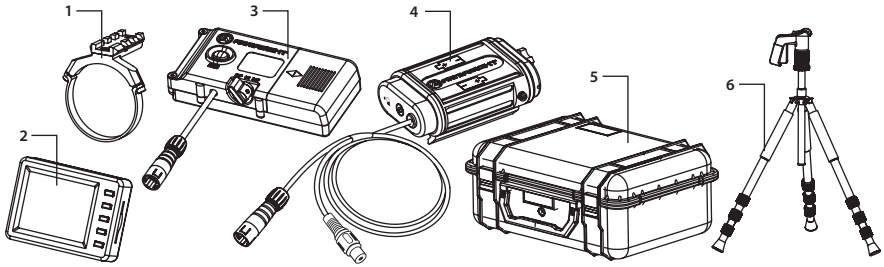

**FIGURE 2-4. OPTIONAL EQUIPMENT**

The ITEM NO. column indicates the number used to identify items in Figure 2-4.

The PART NO. column indicates the primary number used by the manufacturer, to identify an item.

**TABLE 2-9. OPTIONAL EQUIPMENT**

ITEM NO.	DESCRIPTION	PART NO.
1	<b>Platform Ring</b> A dedicated mount with a Picatinny/ Weaver rail, used to install the additional equipment on the Prometheus.	ATAM000003
2	<b>HD DVR Digital Video Recorder</b> High Definition Digital Recorder for all Armasight High Performance Digital and Thermal Devices.	ATAM000005
3	<b>Digital Video Recorder DT</b> A compact digital system used for video recording, storage and playback. Can also serve as an external power source. Equipped with a remote control.	ATAM000004
4	<b>Extended Battery Pack</b> The power source for extended operational time. Takes four CR123A Lithium batteries (3V), CR123 rechargeable batteries (3.2V or 3.7V), or two 18650 rechargeable batteries (3.7V).	ATAM000008
5	<b>Hard Shipping/ Storage Case</b> A protective case used for the shipping/storage of the Prometheus and its accessories.	ANH000001
6	<b>Tripod with a Grip</b> Lightweight and compact tripod used to produce a stable image for long range observation or photo shoot with long exposures.	ANAMTM0003



## 2.5 KEY FEATURES

- Multiple versions with optical magnifications ranging from 1x to 3x
- High-performance thermal imaging camera
- Lightweight and robust design
- Easy to operate
- Manually adjustable eyepiece and objective lens
- Real-time display
- Digitally controlled features:
  - Palette
  - Enhancement
  - Settings
  - Display Brightness
  - Electronic Magnification
  - User-Controlled Manual Non-Uniformity Correction/ Flat-Field Correction (UCMNUC/ FFC)
- Current operational state information display (battery status, active profile, palette setting)
- Wireless remote control
- Analog video input and output (NTSC/PAL)
- Powered by two standard CR123A batteries
- Power input capability
- Digital video recorder (optional)
- Serviceability under severe conditions
- Filled with dry nitrogen to prevent internal fogging
- Water and fog-resistant
- Limited 3-year warranty
- 10-year warranty on FLIR detector

# OPERATING INSTRUCTIONS

## 3.1 INSTALLATION AND MOUNTING

### 3.1.1 BATTERY INSTALLATION

**CAUTION:**

Verify that the equipment is OFF before installing the batteries.

To install two CR123A batteries (refer to Figure 3-1):

1. Unscrew the battery cap (A).
2. Remove the battery cassette (B).
3. Insert the batteries (C) into the cassette. Align the polarity symbols on the batteries with the polarity symbols on the cassette.
4. Insert the cassette with installed batteries.
5. Replace the battery cap.

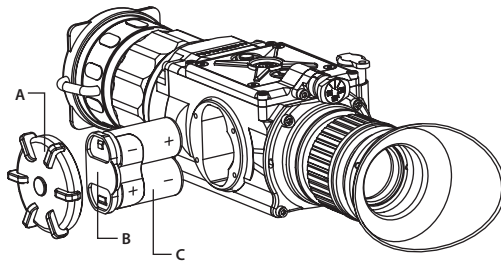
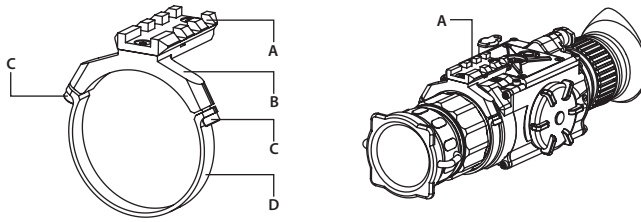

**FIGURE 3-1. BATTERY INSTALLATION**

### 3.1.2 MOUNTING A PLATFORM RING

To mount the Platform Ring (optional) on the Prometheus (refer to Figure 3-2):

1. Using a 1.5 hex key, unscrew both clamp screws (C).
2. Place the clamps (B, D) onto the mounting tube. Screw the clamps together without tightening the screws (C).
3. Adjust the position of the Platform Ring until its rail (A) is level. Apply a small amount of threadlock to the threads and tighten the screws (C).

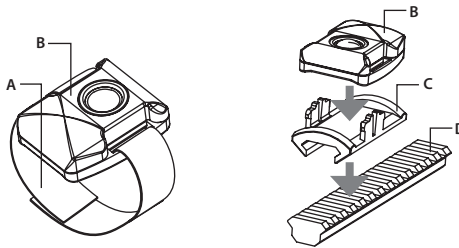

**FIGURE 3-2. PLATFORM RING**

### 3.1.3 FASTENING AN ADVANCED WIRELESS REMOTE CONTROL

Using the supplied Velcro tape (A, Figure 3-3), fasten the remote control (B) to an easily accessible place.

You can use the Picatinny adapter for the Advanced Wireless Remote (C) for mounting the remote control to Picatinny or Weaver rail. Install the adapter onto the rail (D). Insert the remote control into the adapter.



**FIGURE 3-3. ADVANCED WIRELESS REMOTE CONTROL**

### 3.1.4 INSTALLING ADDITIONAL EQUIPMENT

Use the side Picatinny/ Weaver rail to install any additional equipment, such as the Armasight Digital Video Recorder or the Extended Battery Pack.

Use a Platform Ring (optional) to install any additional equipment. For adapter mounting procedures, see Part 3.1.2.

### 3.1.5 CONNECTING AN ADDITIONAL EQUIPMENT

**CAUTION:**

Turn off the Prometheus before you begin connecting/ disconnecting any external equipment and before removing the batteries.

Remove the connector's protective cap.

Connect the cable of Armasight Digital Video Recorder or the Extended Battery Pack to the Prometheus connector.

Use plug A (Figure 3-5) of the video cable to connect an external video recorder/ monitor/ TV to the Prometheus. Connect plug C of the video cable to the Prometheus connector.

Use plug B of the video cable to connect an external power source (6VDC/ 600mA) to the Prometheus. Connect plug C of the video cable to the Prometheus connector.

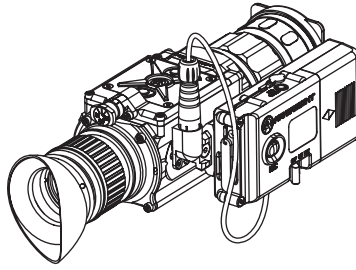

**FIGURE 3-4. ARMASIGHT DIGITAL RECORDER DT INSTALLATION**

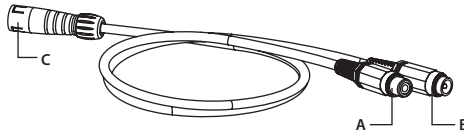

**FIGURE 3-5. VIDEO CABLE**

**NOTE:**

The external power supply must have a standard OD double-pole socket with a positive center contact.

**CAUTION:**

After removing the cable, replace the protective cap over the connector.

### 3.1.6 INSTALLING THE PROMETHEUS ON A TRIPOD

To mount the Prometheus to a tripod, screw the tripod into the 1/4" threaded socket located on the bottom of the Prometheus.

**CAUTION:**

The unit may be badly damaged if the tripod collapses or falls over. Remove the unit from the tripod if it is not within your reach.

## 3.2 CONTROLS AND DISPLAY INDICATIONS

### 3.2.1 CONTROLS

**CAUTION:**

DO NOT force the equipment controls past their stopping points.

The Prometheus controls are shown in Figures 3-6 and 3-7 and are defined in Tables 3-1 and 3-2. The ITEM NO. columns indicate the numbers used to identify items in the figures.

**NOTE:**

Various display symbols indicating the current operating state of the Prometheus can be displayed permanently, may appear momentarily, or can be set to appear only when a certain function is activated.

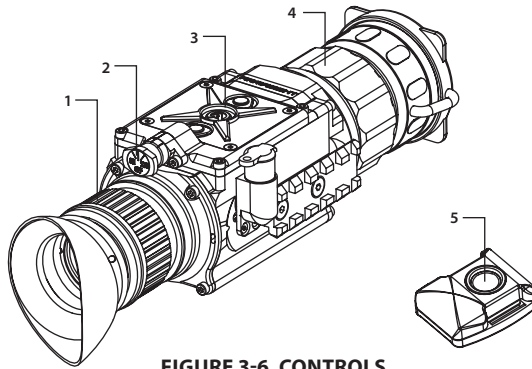

**FIGURE 3-6. CONTROLS**

**TABLE 3-1. CONTROLS AND INDICATORS**

ITEM NO.	CONTROL/INDICATOR	FUNCTION
1	Eyepiece Focus Ring	Adjusts the eyepiece diopter. The total diopter adjustment range is covered with 2 turns of the ring.
2	Turn-Pull Switch	Activates the Prometheus when turned ON. <b>NOTE:</b> You must pull the knob before turning in order to use either ON or STB. Activates standby mode when turned to STB (see note above). Deactivates the Prometheus when turned OFF.
3	Control Panel Buttons	Configures operational settings. See Table 3-2 for button functions.
4	Objective Focus Ring (42mm Lens only)	Focuses the objective lens. Adjusts for sharpest view of the scene. The total focus range is covered with three quarter turns of the lens.
5	Remote Control Button	Activates/ deactivates the Prometheus in standby mode. To turn the unit on, press button once, to turn it off – press button again. To operate the device in short-time activation mode, press and hold the remote control button down for 1.5+ seconds. Release the remote control button to deactivate the device. <b>NOTE:</b> Devices manufactured before 2016 do not have the short-time activation mode.
—	Battery Status Indicator (Battery icon in the top right hand corner of the display)	The color fill (green/ yellow/ red) bar in the battery icon indicates the current power level of the internal battery, or remaining battery life. The totally shaded battery icon indicates the fully charged battery. The flashing transparent battery icon indicates a low battery.

The Prometheus button control panel is shown in Figure 3-7.

Table 3-2 contains the button functions and their brief descriptions. The ITEM NO. column of the table indicates the number used to identify buttons in Figure 3-7.

**NOTE:**

Each button is responsible for some functions selected by briefly pushing or holding down the button, or using the button in combination with a second one (as described in Table 3-2). Pushing a button for 1.5+ second is considered "holding down."

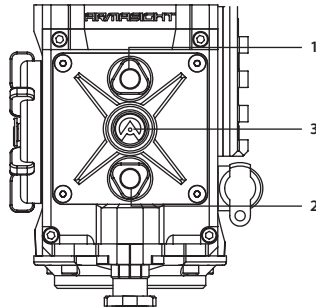

**FIGURE 3-7. BUTTON CONTROL PANEL**

**TABLE 3-2. BUTTON CONTROLS**

ITEM NO.	FUNCTION	DESCRIPTION
1	DISPLAY BRIGHTNESS INCREASE	Push button (1) to increase the screen brightness.
	DIGITAL ZOOM CONTROL UP	To change the zoom gradually, push and hold button (1). Use the UP (1) button to navigate through the items on the menu.
	DISPLAY BRIGHTNESS DECREASE	Push button (2) to decrease the screen brightness.
2	IMAGE PALETTE CONTROL	To scroll through the available palettes, hold down button (2). There are 13 palettes available: White Hot, Black Hot, Fusion, Rainbow, Globow, Ironbow1, Ironbow2, Sepia, Color1, Color2, Ice-Fire, Rain, and OEM.
	DOWN	Use the DOWN (2) button to navigate through items on the menu.
1 + 2	USER-CONTROLLED MANUAL NON-UNIFORMITY CORRECTION/ FLAT-FIELD CORRECTION (UCMNUC/FFC)	Simultaneously holding down buttons (1) and (2) induces User-Controlled Manual Non-Uniformity Correction/ Flat-Field Correction (UCMNUC/ FFC).
3	MENU	Holding down button (3) will bring up the Main Menu. The menu includes the following functions: Palette, Enhancement, and Settings.
	SELECTION	Push the SELECTION button (3) to view the settings available for the item selected. To enable left and right navigation (< >) press button (3).
	UCMNUC/ FFC PROCESS INTERRUPTION	Pushing button (3) when the countdown is on the screen will cancel the UCMNUC/ FFC , and the shutter will not interrupt viewing.

### 3.2.2 MAIN MENU

Most setup options can be accessed from the MAIN MENU.

To display the MAIN MENU, hold down button (3) on the control panel (Figure 3-7).

Once the MAIN MENU is displayed (Figure 3-8), use buttons (1) and (2) to navigate through items on the menu.

Push button (3) to view the settings available for the item selected.

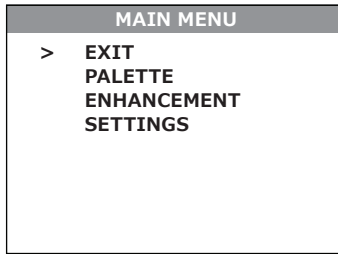

**FIGURE 3-8. MAIN MENU**

To display the MAIN MENU, hold down button (3) on the control panel (Figure 3-7).

Once the MAIN MENU is displayed (Figure 3-8), use buttons (1) and (2) to navigate through items on the menu.

Push button (3) to view the settings available for the item selected.

**NOTES:**

Navigate through sub-menu items by pushing buttons (1) and (2), except where otherwise indicated.

After a menu item is selected, push button (3) to activate the selected function. The function will either be activated or will show <> symbols.

When <> symbols are shown on the menu, the left and the right actions are required. Use button (1) to increase (>) the value, and button (2) to decrease (<) the value. To enter the value and disable left and right navigation, press button (3).

Select EXIT and push button (3) to return to the MAIN MENU.

**Palette Menu**

The PALETTE menu (Figure 3-9 and Figure 3-10) allows you to select from a range of temperature imaging modes: White Hot, Black Hot, Fusion, Rainbow, Globow, Ironbow 1, Ironbow 2, Sepia, Color 1, Color 2, Ice-Fire, Rain, and OEM Custom.

**NOTE:**

To navigate through the items on the two-page PALETTE menu, hold down button (1) or button (2).

The palettes act as color templates for visualization of temperature changes. To navigate through the items on the PALETTE menu, press buttons (1) or (2).

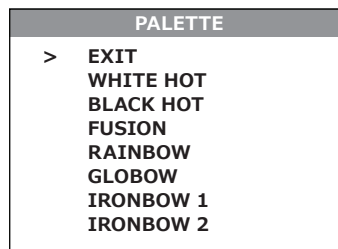

**FIGURE 3-9. PALETTE MENU**

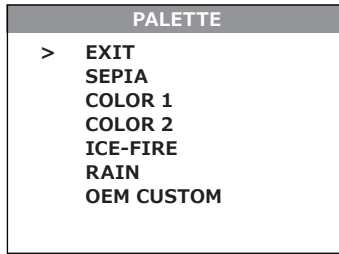

**FIGURE 3-10. PALETTE MENU. CONTINUED**

**NOTE:**

The most popular palettes are White Hot and Black Hot, usually known as inversion. White Hot mode is ideal for spotting targets, while Black Hot is most useful for situational reading.

**NOTE:**

Training and experience are required to quickly and properly interpret thermal images.

**Enhancement Menu**

The ENHANCEMENT menu (Figure 3-11) allows users to take advantage of advanced signal processing algorithms to improve image quality under a variety of different thermal environments.

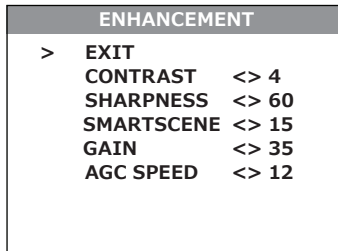

**FIGURE 3-11. ENHANCEMENT MENU**

**CONTRAST** - Active Contrast Enhancement (ACE) – a digital contrast correction that allows for a smart scene optimization based on dynamic adjustments, where a variety of contrast levels occur depending on relative scene temperatures. The adjustment range is from -8 to +8 with a default value of 4. Lower values will cause hotter objects to have greater contrast, and higher values will cause colder objects to have more contrast.

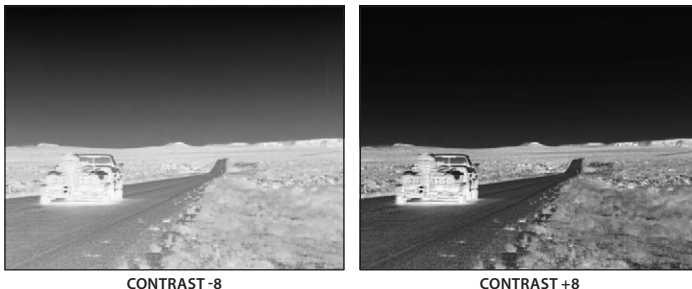

**FIGURE 3-12. DIGITAL CONTRAST CORRECTION**



**SHARPNESS** - Second Generation Digital Detail Enhancement (DDE) – a sharpness correction that digitally enhances the picture, significantly sharpens the image, and further reduces image noise. The adjustment range is from -20 to +100 with a default value of 60. Lower values soften image edges. Higher values will sharpen the image, enhance details, and further increase the signal-to-noise ratio.



**FIGURE 3-13. SHARPNESS CORRECTION**

**SMART SCENE** - Smart Scene Optimization (SSO) – a fine-tuning computational correction that significantly improves overall visual acuity for targets that have thermal signatures similar to the surrounding background. Higher values provide a more linear automatic gain control behavior and objects with similar, but not identical, temperatures can be differentiated with greater accuracy. The adjustment range is from 0 to 100 with a default value of 15.

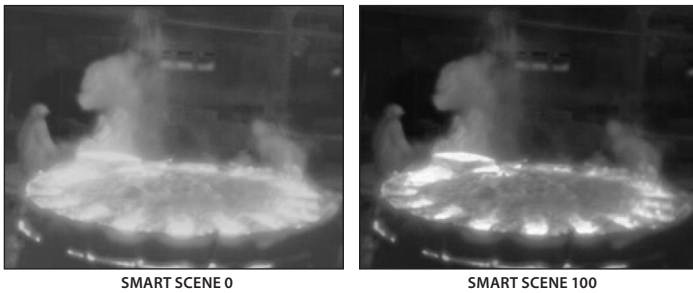

**FIGURE 3-14. SMART SCENE OPTIMIZATION**

**GAIN** - Automatic Gain Control (AGC) – a correction that used to automatically adjust the gain to an appropriate range, the weaker the image signal, the stronger the gain. The adjustment range is from 0 to 255 with default value 35.

**AGC SPEED** – parameter that allows user to control the refresh rate of Automatic Gain Control (AGC). The adjustment range is from 0 to 128 with a default value of 12.



**FIGURE 3-15. GAIN CORRECTION**

## Settings Menu

The SETTINGS menu (Figure 3-16) allows for direct changes to Video Standards and Factory Default settings.

The Firmware (FW) revision number is listed at the bottom of the menu display.

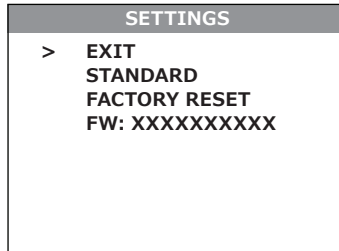

FIGURE 3-16. SETTINGS MENU

### STANDARD

Changes the video output standard between NTSC and PAL.

### FACTORY RESET

Resets the camera to factory defaults.

### SOFTWARE VERSION

Software release is shown in alphanumeric format. When the SELECT button is pushed, the FW (firmware) version will appear.

#### **NOTE:**

After configuration is complete, select EXIT on the MAIN MENU and push button (3). All settings will be saved.

## 3.3 OPERATING PROCEDURES

### 3.3.1 OPERATING

#### **CAUTION:**

DO NOT force the equipment controls past their stopping points.

#### **CAUTION:**

To prevent thermal damage to the equipment, never point it, either powered or not, directly at the sun or any other source of high intensity light that the unprotected human eye cannot tolerate (such as a welding arc). To prevent inadvertent exposure to these sources, never leave the equipment without the objective lens cap secured.

Operating procedures are as follows:

1. Remove the Prometheus from the carrying case.
2. Remove the objective lens cap.
3. Point the equipment at an object.

4. Activate the Prometheus by turning the turn-pull switch ON. After approximately 3 sec, video of the thermal scene should appear.
5. Adjust the Prometheus for your eyesight by turning the eyepiece focus rings CW up to the stop, and then CCW until the display and symbols are as clear as possible. Bring the object into focus by turning the objective focus ring (42mm objective lens only)(CW for far focus, CCW for near focus).

**NOTE:**

The total diopter adjustment range is covered with 2 turns of the eyepiece focus ring.  
The total focus range is covered with three quarter turns of the objective focus ring.

6. Using the buttons on the control panel (Figure 3-17), configure the Prometheus to adapt it to your situation.

For more information on operational setting procedures, see Part 3.2 (Controls and Display Indications).

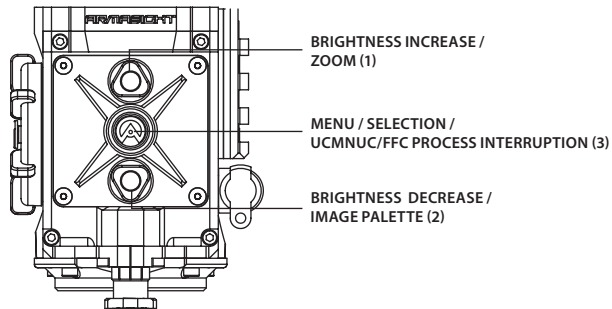

**FIGURE 3-17. SETTING BUTTONS**

- A. Adjust the brightness of the display for your comfort.

Push buttons (1) and (2) to increase/ decrease the display brightness by one level at a time until you reach your desired brightness level.

- B. Use UCMNUC/ FFC (User-Controlled Manual Non-Uniformity Correction/ Flat-Field Correction) to improve image quality.

Push buttons (1) and (2) simultaneously to start manual UCMNUC/ FFC.

If necessary, interrupt the automatic process by pushing the central button (3) on the control panel during the 5-second countdown, which will appear at the bottom of the display.

- C. Use the digital zoom to magnify the central area of the image.

Hold down button (1) to slowly zoom in on the image. The X1, X2, X4, and X8 symbols (maximum zoom factor is dependent on equipment model) will appear in the lower part of the display.

**NOTE:**

Digital zoom allows distant objects to appear larger; however, the resolution will be compromised.

- D. Use the image palettes for optimal visualization of temperature changes in the scene.

Hold down the palette control button (2) to scroll through available palettes. The palette name will appear in the top part of the display.

- E. Adjust the necessary adjustment using the MAIN MENU. See Part 3.2.2 (Using the MAIN MENU).

**NOTE:**

After configuration is complete, select EXIT on the MAIN MENU and push the SELECTION button to leave the MAIN MENU. All settings will be saved.

10. To operate the Prometheus with Advanced Wireless Remote Control (AWREC), turn the function switch to the STB position (Standby). After it the Remote Control button can activate/ deactivate the device in two ways:

- 1) To turn the device on, press the remote control button once, to turn it off – press the button again.
- 2) To operate the device in short-time activation mode (see note below), press and hold the remote control button down for 1.5+ seconds. Release the remote control button to deactivate the device.

**NOTE:**

Devices manufactured before 2016 do not have the short-time activation mode.

**CAUTION:**

DO NOT leave the equipment activated when not in use.

### 3.3.2 PROMETHEUS SHUT-DOWN

**NOTE:**

Shut down the Prometheus properly to avoid losing unsaved settings and data.

Shut-down the Prometheus as follows:

1. Be sure to save your settings and data.
2. Turn off the Prometheus.
3. Place the protective cap on the objective lens.
4. Disconnect the cable (if applicable).
5. Place the protective cap on the connector.
6. Remove the batteries.

**CAUTION:**

Do not store the Prometheus with the batteries still installed.

7. Store the Prometheus and all accessories in the carrying case.

# PREVENTIVE MAINTENANCE AND TROUBLESHOOTING

## 4.1 PREVENTIVE MAINTENANCE CHECKS AND SERVICES

### 4.1.1 PREVENTIVE MAINTENANCE CHECKS AND SERVICES (PMCS)

Table 4-1 Preventive Maintenance Checks and Services (PMCS), has been provided so that you can keep your equipment in good operating condition.

Perform functional tests in the order listed in Table 4-1.

Operating procedures are detailed in Chapter 3.

#### Explanation of Table Entries:

**SEQ NO. column.** Sequence numbers are for reference and appear in the order required to perform checks and services.

**LOCATION OF ITEM TO CHECK/ SERVICE column.** Indicates the location and the item to be checked or serviced.

**PROCEDURE column.** Details the check/ service procedure.

**NOT FULLY MISSION CAPABLE IF... column.** Indicates what faults will prevent your equipment from operating successfully.

**TABLE 4-1. PREVENTIVE MAINTENANCE CHECKS AND SERVICES**

SEQ NO.	LOCATION OF ITEM TO CHECK/ SERVICE	PROCEDURE	NOT FULLY MISSION CAPABLE IF...
PRE-OPERATION CHECKS			
1	Completeness	Open storage/ carrying case and inventory items by comparing with the data in this manual.	Missing items.
2	Soft Carrying Case	Shake out loose dirt or foreign material. Inspect for tears, cuts, excess wear or damage.	
3	Body	Inspect for cracks or damage. Scratches and gouges are OK if operation is not affected. Inspect for missing parts. Clean as required.	Cracked or damaged. Missing parts.
4	Objective Lens Cap	Inspect for cuts, tears and dirt. Clean as required.	Cap is torn or cut. Cap is not secured to the housing of the lens.

**TABLE 4-1. CONTINUED**

<b>SEQ NO.</b>	<b>LOCATION OF ITEM TO CHECK/ SERVICE</b>	<b>PROCEDURE</b>	<b>NOT FULLY MISSION CAPABLE IF...</b>
5	Eyeclip	Inspect for cuts, tears and dirt. Inspect for torn, bent or improperly fitting eyeclip. Clean as required.	Cup is torn or cut.
6	Battery Compartment and Cap	Inspect for corrosion, moisture, and corroded or defective contacts. Inspect for cap damage or retainer breaks. Inspect rubber gasket for damage.	Contacts are damaged or corroded. Retainer is broken. Cap or rubber gasket is damaged.
7	Lenses	Inspect for cleanliness, scratches, chips or cracks. Clean as required.	Chipped or cracked. Scratches hinder vision through the equipment.
8	Objective Focus Ring (42mm Lens only)	Rotate objective focus ring to ensure it is not too tight or too loose. Range is approximately three quarter turns.	Ring gets stuck, is too loose, or adversely affects the user's ability to properly focus the objective lens.
9	Eyepiece Focus Ring	Rotate eyepiece focus ring to ensure the ring is not too tight or too loose. Range is approximately 2 turns.	Ring get stuck, is too loose, or adversely affect the user's ability to properly adjust the diopter.
10	Turn-Pull Switch	Check for operation (without batteries).	Switch is inoperative.
11	Connector	Inspect for corrosion, moisture, and corroded or defective contacts. Inspect for cap damage or retainer breaks.	Contacts are damaged or corroded. Cap is damaged. Retainer is broken.
12	Remote Control Unit	Check for damage and missing parts. Check Velcro tape for wear.	Damaged. Missing parts.
13	Video Cable	Inspect for damage. Inspect the cable connector for corrosion, moisture, and corroded or defective contacts. Clean as required.	Damaged.
14	Platform Ring (optional)	Inspect for damage, corrosion, or missing parts. Check for proper operation. Clean as required.	Damaged. Missing parts.

**OPERATIONAL CHECKS**

**NOTE:**

For a complete operational check, it is necessary to connect a video monitor to the Prometheus.

16	Turn-Pull Switch	Install the batteries. Remove the objective lens cap. Point the equipment at an object. Turn the equipment on. Look for a thermal image on the display. Look for a flashing battery icon in the eyepiece viewing area.	No thermal image. Battery icon is flashing (indicates a low battery).
17	Control Board	Ensure the Prometheus is responsive to control buttons.	Unresponsive buttons.
18	Remote Control	Turn the equipment to standby. Point the equipment at an object. Push and hold the remote control button. Look for a thermal image on the display. Release the button. Turn off the equipment.	No image.
19	Video Cable	Connect an external monitor to the Prometheus. Point the equipment on an object. Turn the equipment on. Look for an image on the monitor. Turn off the Prometheus. Disconnect the monitor.	No image.

**POST-CHECK PROCEDURES**

- Turn off the equipment.
- Replace the objective lens cap.
- Remove the batteries.
- Return the equipment and all accessories to the carrying case.

## 4.2 OPERATOR TROUBLESHOOTING

The purpose of troubleshooting is to identify the most frequent equipment malfunctions, probable causes, and corrective actions required.

Table 4-2 lists the common malfunctions that may be found during the operation or maintenance of the Prometheus. Perform the tests/inspections and corrective actions in the order listed.

**This table does not list all of the malfunctions that may occur with your device, or all of the tests and corrective actions that may be necessary.** If you experience an equipment malfunction that is not listed, or is not fixed by the corrective actions listed in the table, please contact Armasight's Customer Service center.

**TABLE 4-2. OPERATOR TROUBLESHOOTING**

MALFUNCTION	PROBABLE CAUSE/ TEST/INSPECTION	CORRECTIVE ACTION
The Prometheus fails to activate.	Batteries are missing or improperly installed.	Insert batteries or install correctly.
	Batteries are dead.	Replace the batteries.
	Batteries, surfaces, or contacts are dirty or corroded.	Clean the contact surfaces with a pencil eraser and/or alcohol and cotton swabs.
	Remote control unit is damaged.	Please contact Customer Support.
	Remote control battery is dead.	Replace the battery as per Part 4.3.4.
The equipment is damaged.		Please contact Customer Support.
The Prometheus is not responsive to control buttons.	The equipment is damaged.	Please contact Customer Support.
Remote control does not work.	Battery is missing or improperly installed.	Insert battery or install correctly.
	Battery is dead.	Replace the battery.
	Battery surfaces or contacts are dirty or corroded.	Clean the contact surfaces with a pencil eraser and/or alcohol and cotton swabs.
	Remote control unit is damaged.	Please contact Customer Support.
Poor image quality.	Check objective lens and eyepiece focus.	Refocus.
	Check for fogging or dirt on objective lens and eyepiece.	Clean the lenses as detailed in Part 4.3.2.
	The equipment is damaged.	Please contact Customer Support.
No image on an external monitor.	Video cable is damaged.	Replace the video cable with a new one. If this is not effective, please contact Customer Support.
	The equipment is damaged.	Please contact Customer Support.
Hindered rotation of the battery cap.	Dirty cap thread.	Clean the thread.
	Damaged cap thread.	Replace the cap with a new one. If this is not effective, please contact Customer Support.
Light is visible around eyecup.	Check eyecup resilience.	If the eyecup is defective, please contact Customer Support.

## 4.3 MAINTENANCE

### 4.3.1 GENERAL

The Prometheus operator maintenance consists of operational tests, inspections for unit serviceability, cleaning and mounting procedures, and corrective actions (troubleshooting and replacement of a limited number of parts). Maintenance instructions covered elsewhere in this manual (PMCS, troubleshooting, etc.) are not repeated in this section.

**CAUTION:**

The Prometheus is a precision electro-optical instrument and must be handled carefully at all times to prevent damage.

**CAUTION:**

DO NOT dismantle the equipment.

### 4.3.2 CLEANING PROCEDURES

Clean the Prometheus and optional items as follows:

1. Gently brush off any dirt from the equipment using only a clean, soft cloth.
2. Moisten the cloth with fresh water and gently wipe the external surfaces (except for optical surfaces).
3. Dry any wet surfaces (except for optical surfaces) with another clean, dry soft cloth.
4. Using a lens brush, carefully remove all loose dirt from optical surfaces (objective lens and eyepiece).
5. Dampen a cotton swab with ethanol and lightly and slowly wipe optical surface. Clean the optical surface using circular movements, starting from the center and moving out towards the edge, not touching the lens holder and changing the cotton swab after each circular stroke. Repeat until the optical surface is clean.
6. Clean the battery contact surfaces and contact springs with a pencil eraser and/or alcohol and cotton swabs.

**CAUTION:**

Thoroughly dry each item before replacing into the storage/carrying case.

### 4.3.3 BATTERY REMOVAL AND REPLACEMENT

Refer to Part 3.1.1 for battery installation procedures.

Replace the remote control battery as follows:

1. Using a screwdriver, unscrew the four screws (A, Figure 4-1) that secure the cover to the bottom of the unit. Remove the cover.

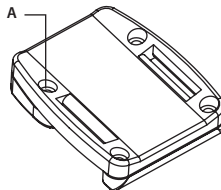

**FIGURE 4-1. ADVANCED WIRELESS REMOTE CONTROL BATTERY INSTALLATION**



2. Replace the battery with new one (CR2032, 3V). Install the battery, aligning their polarity markings (+/-) with those embossed on the compartment.
3. Replace the cover and tighten the screws (A).

## 4.4 RETURN INSTRUCTIONS

For service, repair or replacement, please email [service@armasight.com](mailto:service@armasight.com).

To assist the Service Representative (SR) with determining if the item is repairable, please provide the following information:

1. Serial Number of the defective item (engraved on bottom of the equipment).
2. Thorough description of the malfunction, defect, or damage.
3. An explanation of how the malfunction, defect, or damage occurred, if known.

If the SR determines that the item is under warranty or should be returned for repair, a Return Material Authorization number (RMA#) will be provided.

When returning the Prometheus for service or repair, the following procedures should be followed to prevent any additional damage:

1. Make sure the Prometheus is free of all contaminants such as dirt or any other foreign material.
2. Remove the batteries.
3. Place the cap over the objective lens.
4. Place the Prometheus and accessories in the carrying case.

Place the Prometheus and a copy of the test report or detailed description of the failure in a suitable packing/shipping container. Mark the package with the RMA#. Ship the fastest, traceable, prepaid means to:

Armasight Inc.  
815 Dubuque Avenue  
South San Francisco, CA 94080  
USA

**A. PRODUCT WARRANTY REGISTRATION CARD**

In order to validate the warranty on your product, Armasight must receive a completed Product Warranty Registration Card for each unit, or the user must complete warranty registration on our website ([www.armsight.com](http://www.armsight.com)). Please complete the included form and immediately mail it to our Service Center:

Armasight Inc.  
 815 Dubuque Avenue  
 South San Francisco, CA 94080  
 USA

**ARMASIGHT PRODUCT WARRANTY REGISTRATION CARD**

**PRODUCT INFORMATION**

Product Name \_\_\_\_\_ Purchased From \_\_\_\_\_

Purchase Date \_\_\_\_\_ Product Serial # \_\_\_\_\_

**CUSTOMER INFORMATION**

Name \_\_\_\_\_

Address \_\_\_\_\_

City \_\_\_\_\_ Country \_\_\_\_\_ Zip \_\_\_\_\_

Day Phone # \_\_\_\_\_ Home Phone # \_\_\_\_\_

E-mail address \_\_\_\_\_

.....  
 Customer Signature Required

## B. LIST OF SPARE PARTS

The parts authorized by this list of spare parts are required for operator maintenance. The list includes parts that must be removed before replacing authorized parts.

The PART NO. column indicates the primary number used by the manufacturer, which controls the design and characteristics of the item in terms of its engineering drawings, specifications, standards, and inspection requirement, to identify an item.

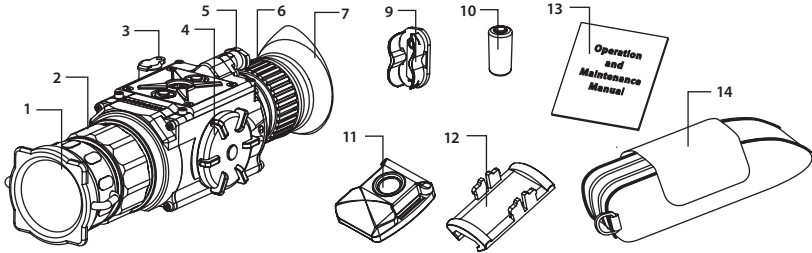

**FIGURE B-1. PROMETHEUS SPARE PARTS LIST**

**TABLE B-1. PROMETHEUS SPARE PARTS LIST**

ITEM NO.	DESCRIPTION	PART NO.
1	25mm Objective Lens Cap	APRMOLC25
-	42mm Objective Lens Cap	APRMOLC42
2	25mm Objective Lens Assembly	APRMOLA25
-	42mm Objective Lens Assembly	APRMOLA42
3	Connector Cap	APRMCNCP
4	Battery Cap	APRMBC
5	Turn-pull Switch	APRMSWT
6	Eyepiece Assembly	APRMEPA
7	Eyecup	APRMEC
8	Side Picatinny/ Weaver Rail	APMRRL
9	Battery Cassette	ARRMBTCS
10	CR123A Lithium Battery	ALT
11	Advanced Wireless Remote Control	ANVR000001
12	Picatinny Adapter for Advanced Wireless Remote Control	ANRA000002
13	Operation and Maintenance Manual	APROMMM
14	Carrying Case	APRMCCS



Armasight Inc.

815 Dubuque Avenue  
South San Francisco  
CA 94080, USA

Phone: (888)959-2259

Fax: (888)959-2260

Intl Phone/Fax: (650)492-7755

[info@armasight.com](mailto:info@armasight.com)



**WARNING!**

**This product contains natural rubber latex which may cause allergic reactions!** The FDA has reported an increase in the number of deaths that are associated with an apparent sensitivity to natural latex proteins. If you are allergic to latex, it is a good idea to learn which products contain it and strictly avoid exposure to those products.

[www.armasight.com](http://www.armasight.com)