



CO-MINI

Night Vision Clip-On System



OPERATION AND MAINTENANCE MANUAL

Important Export Restrictions! Commodities, products, technologies and services of this manual are controlled by the U.S. Department of State Office of Defense Trade Controls, in accordance with International Traffic in Arms (ITAR), Title 22, Code of Federal Regulations Part 120-130 and/ or by the Export Administration Regulations (EAR) of U.S. Department of Commerce. At any time when a license or a written approval of the U.S. Government is applicable to it, it is illegal and strictly forbidden to export, intend to export, transfer in any other manner whatsoever, sell any hardware or technical data, provide any associated service to any non-U.S. resident, beyond or within the United States territory, until the valid license or written approval has been issued by the Departments of the U.S. Government having jurisdiction. Additionally U.S. law prohibits the sale, transfer, or export of items to certain restricted parties, destinations, and embargoed countries, as identified on lists maintained by the U.S. Department of State, the U.S. Department of Commerce, and the U.S. Department of Treasury. It is the responsibility of the Customer to be aware of these lists. The sale, transfer, transportation, or shipment outside of the U.S. of any product prohibited or restricted for export without complying with U.S. export control laws and regulations, including proper export licensing, documentation or authorization, is unlawful and may result in civil and/or criminal penalties and/or constitute a federal crime. Diversion contrary to U.S. law is strictly prohibited.



SAFETY SUMMARY

Before operating this product, carefully read and study this Operation and Maintenance Manual.

The Armasight CO-MINI Night Vision Clip-On Device is a precision electro-optical instrument and requires careful handling. To avoid physical danger or equipment damage when using the CO-MINI, follow all WARNINGS, CAUTIONS, and NOTES.

Below you will find definitions of the following alerts that appear throughout this Manual:

WARNING – Identifies a clear danger to the person operating the equipment.

CAUTION – Identifies risk of damage to the equipment.

NOTE – Highlights essential procedures, conditions, statements, and important instructional information for the user.



WARNING:

Always make sure your firearm is unloaded before you place the scope on the firearm. Verify that the chamber is empty, particularly if you stop the procedure and resume at a later time. Safe handling rules should be followed at all times.



WARNING:

If a scope is mounted too far to the rear of a weapon, the eyepiece can injure the shooter's brow. Shooting at an uphill angle also increases this risk, because it shortens the distance between the brow and the rear of the scope. When mounting your scope, we recommend positioning it as far forward in the mounts as possible.

With hard-recoiling rifles, serious injury or even death can result from eyepiece impact when discharging the firearm.

BEFORE SHOOTING THE FIREARM, verify that your installation provides sufficient space between the eyepiece and the scope to account for the recoil generated by your rifle.

NOTE: Give special attention to this warning when shooting uphill and/or from a prone position. These shooting conditions can dramatically reduce space allotted for recoil between your eyes and the weapon. PLEASE maintain maximum distance when shooting magnum firearms or firearms with heavy recoil. THE USER ASSUMES ALL RESPONSIBILITY AND LIABILITY FOR HAVING THE RIFLESCOPE PROPERLY MOUNTED TO A FIREARM AND USING THE RIFLESCOPE PROPERLY. ALWAYS CHECK THE CONDITION OF YOUR MOUNTING SYSTEM PRIOR TO USING YOUR FIREARM.



WARNING:

This product contains natural rubber latex which may cause allergic reactions! The FDA has reported an increase in the number of deaths that are associated with an apparent sensitivity to natural latex proteins. If you are allergic to latex, it is a good idea to learn which products contain it and strictly avoid exposure to those products.

The information provided in this manual is for familiarization purposes only. The contents may undergo further changes with no commitment by Armasight® to notify customers of any updates.

Armasight® assumes no responsibility for any misprints or other errors that this manual may contain.

© Armasight Inc. 2015



WARNINGS:

- Armasight recommends using an eyecup on the eyepiece of the day scope for maximum adjustment capabilities and comfort, as well as to prevent inadvertent exposure to other NVDs.
- The light from the infrared illuminator is invisible to the unaided eye. **However, the light can be detected by other night vision devices.**

CAUTION:

- DO NOT dismantle the equipment.
- Keep the equipment clean. Protect it from moisture, dramatic temperature changes, and electric shocks.
- DO NOT drop or hit the equipment.
- Protect the equipment from overexposure to light. DO NOT activate the equipment in daylight with the objective lens cap removed; DO NOT aim the equipment at bright light sources (fire, car headlights, lanterns, street lamps, room lights, etc.).
- DO NOT force the equipment controls past their stopping points.
- DO NOT leave the equipment activated during breaks in operation.
- Verify that the equipment is off before installing a battery.
- DO NOT store the equipment with the battery still in it.
- To avoid deformation or damage, remove the light suppressor from the CO-MINI before placing the equipment in storage.
- Thoroughly clean and dry each item before placing them into the storage case.
- Scope Mounting Systems are **not** recommended for installing the CO-MINI on firearms having vigorous recoil (0.308 Win or stronger).

NOTES:

- The optical axes of the CO-MINI and day scope should align. The distance between the axes should not exceed 2mm. If the difference in the axis heights of the CO-MINI and day scope above the weapon rail exceeds 2mm, you will need to replace the day scope mounting rings or monoblock.
- At operating temperatures below -20°C (-4°F), alkaline battery life will be severely reduced. Under these conditions, the use of lithium battery is recommended.
- The equipment requires some level of ambient light (moonlight, starlight, etc.) to function correctly.
- Performance of the device in nighttime conditions depends on the level of ambient light in the environment. Please remember the following:
 - The level of ambient light is reduced by the presence of clouds, shade, or objects that block natural light (trees, buildings, etc.).
 - The equipment is less effective when operated in shadows and other darkened areas.
 - The equipment is less effective when operated in rain, fog, sleet, snow, dust or smoke.
 - The equipment will not “see” through dense smoke.
- For the purpose of returning defective components, retain all packaging materials.

LIST OF CONTENTS

TITLE	PAGE
Safety Summary	2
List of Contents	4
List of Figures	5
List of Tables	6
How to Use This Manual	6
1. INTRODUCTION	7
1.1 General Information	7
1.1.1 Type of Manual	7
1.1.2 Model Number and Equipment Name	7
1.1.3 Purpose of Equipment	7
1.1.4 Reporting Equipment Improvement Recommendations	7
1.2 Warranty Information and Registration	8
1.2.1 Warranty Information	8
1.2.2 Limitation of Liability	8
1.2.3 Product Warranty Registration	8
1.2.4 Obtaining Warranty Service	9
1.3 Cross References	9
1.4 List of Abbreviations	10
2. DESCRIPTION AND DATA	11
2.1 System Description	11
2.2 Specifications	13
2.3 Standard Components	15
2.4 Optional Equipment	16
2.5 Key Features	17
2.6 System Limitations	17
3. OPERATING INSTRUCTIONS	18
3.1 Installation and Mounting	18
3.1.1 CO-MINI Battery Installation	18
3.1.2 XLR-IR850 Battery Installation	19
3.1.3 Installing the CO-MINI on a Picatinny/ Weaver Rail	19
3.1.4 Clamping Device Adjustment	21
3.1.5 Installing the Quick Release Mount	21
3.1.6 Installing the CO-MINI onto the Lens of a Day Scope	22
3.1.7 Fastening a Remote Control Unit to Weapon	23
3.1.8 Installing the IR Illuminator	24
3.1.9 Installing the 3x Magnifier	24
3.1.10 Installing the Light Suppressor for a Day Scope	25
3.2 Controls and Indicators	25
3.2.1 CO-MINI Controls and Indicators	25
3.2.2 IR Illuminator Controls	26
3.3 Operating Procedures	27
3.3.1 Operating the CO-MINI	27
3.3.2 Operating the IR Illuminator	27

3.3.3 Operating in Changing Light Conditions	28
3.3.4 Shut-Down	28
4. PREVENTIVE MAINTENANCE AND TROUBLESHOOTING	29
4.1 Preventive Maintenance Checks and Services	29
4.2 Operator Troubleshooting	31
4.3 Inspection Criteria for Proper Image Intensifier Tube Operation	31
4.3.1 Operational Defects	31
4.3.2 Cosmetic Blemishes	32
4.4 Maintenance	34
4.4.1 General	34
4.4.2 Cleaning Procedures	34
4.4.3 Battery Removal and Replacement	34
4.5 Return Instructions	35
APPENDIX	36
A. Estimation of Ambient Illumination Level	36
B. List of Spare Parts	36
C. Product Warranty Registration Card	38
Alphabetical Index	39

LIST OF FIGURES

FIGURE	TITLE	PAGE
2-1	CO-MINI Night Vision Clip-On Device as Delivered	11
2-2	CO-MINI Night Vision Clip-On Device	12
2-3	Standard Components	15
2-4	CO-MINI Optional Equipment	16
3-1	The CO-MINI. Battery Installation	18
3-2	Positions of the Adapter in the Battery Cap	19
3-3	The XLR-IR850. Battery Installation	19
3-4	Mount. Top View	20
3-5	Mount. Underside View	20
3-6	The CO-MINI on a Picatinny Rail in Front of a Day Scope	20
3-7	The CO-MINI Ready-assembled with the Riser	21
3-8	Installing the Mount with the Riser	21
3-9	The CO-MINI Installed on the Lens of a Day Scope	22
3-10	Scope Mounting System	22
3-11	Estimation of the Adapter Turning Angle	23
3-12	Remote Control Unit	23
3-13	XLR-IR850 IR Illuminator	24
3-14	XLR-IR850 Illuminator with Afocal Doubler	24
3-15	The CO-MINI with a 3x Magnifier	24
3-16	Light Suppressor for a Day Scope	25
3-17	CO-MINI Controls	25
3-18	IR Illuminator Controls	26
3-19	IR Illuminator Adjustment	28
4-1	Shading	32
4-2	Edge Glow	32

4-3	Emission Points and Bright Spots	33
4-4	Fixed Pattern Noise	33
4-5	Chicken Wire	34
4-6	Remote Control Unit. Battery Installation	35
B-1	CO-MINI Spare Parts	36

LIST OF TABLES

TABLE	TITLE	PAGE
2-1	System Description	12
2-2	System Data	13
2-3	Mechanical Data	13
2-4	Electrical Data	13
2-5	Optical Data	13
2-6	Environmental Data	13
2-7	XLR-IR850 Data	14
2-8	Scope Mounting Systems Data	14
2-9	Standard Components	15
2-10	CO-MINI Optional Equipment	16
3-1	CO-MINI Controls and Indicators	26
3-2	IR Illuminator Controls	26
4-1	Preventive Maintenance Checks and Services	29
4-2	Operator Troubleshooting	31
A-1	Standard Natural Light Conditions and Illumination Values	36
B-1	CO-MINI List of Spare Parts	37

HOW TO USE THIS MANUAL

USAGE

You must familiarize yourself with this entire manual before operating the equipment. Before performing any kind of maintenance on your CO-MINI, read the section on maintenance in its entirety. Follow all WARNINGS, CAUTIONS, and NOTES.

MANUAL OVERVIEW

The Manual contains sections on operating and maintaining the CO-MINI Night Vision Clip-On Device. Throughout this Manual, the Armasight CO-MINI Night Vision Clip-On Device will be referred to as the CO-MINI, "the device", or "the equipment."

Reference data for the estimation of ambient illumination levels can be found in Appendix A.

A list of spare parts appears in Appendix B.

The Product Warranty Registration Card is located in Appendix C.

INTRODUCTION

1.1 GENERAL INFORMATION

1.1.1 TYPE OF MANUAL

Operation and Maintenance (including a List of Spare Parts).

1.1.2 MODEL NUMBER AND EQUIPMENT NAME

CO-MINI Night Vision Clip-On System.

CO-MINI MG Night Vision Clip-On System with Manual Gain Control.

1.1.3 PURPOSE OF EQUIPMENT

The CO-MINI is a night vision system intended to be used for short to medium ranges (normally up to 350 yards) in conjunction with a daytime sight or riflescope (hereafter referred to as a “day scope”). When mounted on a weapon in front of an existing day scope, the CO-MINI adds night vision functionality to the scope’s capabilities, without affecting the boresight.

The CO-MINI is compatible with most commercial and military specification day scopes or binoculars, up to 6X magnification, and fits any Picatinny MIL-STD-1913 or Weaver rail via the quick-release mount. Optional adapters make it possible to mount the CO-MINI directly to the objective lens of a variety of day scopes and binoculars.

A long-range XLR-IR850 infrared illuminator (hereafter referred to as the XLR-IR850) enables use of the CO-MINI in extremely low light conditions or total darkness. Other additional equipment, such as an infrared laser, red dot sight, etc., may also be installed on the CO-MINI.

Additionally, the CO-MINI MG version incorporates gain control, which allows the user to increase or decrease the brightness of the image to compensate for overly bright or extremely dark conditions.

NOTE:

The CO-MINI can also be installed in front of the viewfinders of various instruments to widen the operational illumination range.

1.1.4 REPORTING EQUIPMENT IMPROVEMENT RECOMMENDATIONS

Recommendations from the user for improvements to the device are encouraged.

Mail your comments to Armasight Inc., 815 Dubuque Avenue, South San Francisco, CA 94080, USA.

Or, send an email to service@armasight.com

1.2 WARRANTY INFORMATION AND REGISTRATION

1.2.1 WARRANTY INFORMATION

This product is guaranteed to be free from manufacturing defects in material and workmanship under normal use for a period of two (2) years from the date of purchase. In the event that a defect covered by the below warranty occurs during the applicable period stated above, Armasight, at its discretion, will either repair or replace the product; such action on the part of Armasight shall be the full extent of Armasight's liability, and the Customer's sole and exclusive reparation. This warranty does not cover a product if it has (a) been used in ways other than its normal and customary manner; (b) subjected to misuse; (c) subjected to alterations, modifications or repairs by the Customer or by any party other than Armasight without prior written consent of Armasight; (d) special order or "close-out" merchandise or merchandise sold "as-is" by either Armasight or the Armasight dealer; or (e) merchandise that has been discontinued by the manufacturer and either parts or replacement units are not available due to reasons beyond the control of Armasight. Armasight shall not be responsible for any defects or damage that in Armasight's view are a result from the mishandling, abuse, misuse, improper storage or improper operation of the device, including use in conjunction with equipment that is electrically or mechanically incompatible with, or of inferior quality to, the product, as well as failure to maintain the environmental conditions specified by the manufacturer. CUSTOMER IS HEREBY NOTIFIED THAT OPERATION OF THE EQUIPMENT DURING DAYLIGHT HOURS OR UNDER ANY EXCESSIVE LIGHT CONDITIONS MAY PERMANENTLY DAMAGE THE INTERNAL COMPONENTS OF THE UNIT AND SAID DAMAGE WILL NOT BE COVERED UNDER THIS WARRANTY. This warranty is extended only to the original purchaser. Any breach of this warranty shall be enforced unless the Customer notifies Armasight at the address noted below within the applicable warranty period.

The Customer understands and agrees that except for the foregoing warranty, no other warranties written or oral, statutory, expressed or implied, including any implied warranty of merchantability or fitness for a particular purpose, shall apply to the product. All such implied warranties are hereby and expressly disclaimed.

1.2.2 LIMITATION OF LIABILITY

Armasight will not be liable for any claims, actions, suits, proceedings, costs, expenses, damages or liabilities arising out of the use of this product. Operation and use of the product are the sole responsibility of the Customer. Armasight's sole undertaking is limited to providing the products and services outlined herein in accordance with the terms and conditions of this Agreement. The provision of products sold and services performed by Armasight to the Customer shall not be interpreted, construed, or regarded, either expressly or implied, as being for the benefit of or creating any obligation toward any third party of legal entity outside Armasight and the Customer; Armasight's obligations under this Agreement extend solely to the Customer. Armasight's liability hereunder for damages, regardless of the form or action, shall not exceed the fees or other charges paid to Armasight by the Customer or Customer's dealer. Armasight shall not, in any event, be liable for special, indirect, incidental, or consequential damages, including, but not limited to, lost income, lost revenue, or lost profit, whether such damages were foreseeable or not at the time of purchase, and whether or not such damages arise out of a breach of warranty, a breach of agreement, negligence, strict liability or any other theory of liability.

1.2.3 PRODUCT WARRANTY REGISTRATION

In order to validate the warranty on your product, Armasight must receive a completed Product Warranty Registration Card for each unit, or the Customer can complete a warranty registration on our website, at www.armsight.com. Please complete the included form (Appendix C) and immediately mail it to our Service Center:

Armasight Inc.
815 Dubuque Avenue
South San Francisco
CA 94080
USA

1.2.4 OBTAINING WARRANTY SERVICE

To obtain warranty service on your unit, the End-User (Customer) must notify the Armasight service department via email. Send any requests to service@armasight.com to receive a Return Merchandise Authorization number (RMA). When returning any device, please take in the product to your retailer, or send the product, postage paid and with a copy of your sales receipt, to Armasight Corporation's service center at the address listed above. All merchandise must be fully insured with the correct postage; Armasight will not be responsible for improper postage or merchandise that becomes lost or damaged during shipment. When sending product back, please clearly write the RMA# on the outside of the shipping box. Please include a letter that indicates your RMA#, the Customer's Name, a Return Address, reason for the return, Contact information (valid telephone numbers and/or an e-mail address), and proof of purchase that will help us to establish the valid start date of the warranty. Product merchandise returns that do not have an RMA# listed may be refused, or a significant delay in processing may occur. Estimated Warranty service time is 10-20 business days. The End-User/ Customer is responsible for postage to Armasight for warranty service. Armasight will cover return postage/ shipping after warranty repair to the End-User/ Customer only if the product is covered by the aforementioned warranty. Armasight will return the product after warranty service by domestic UPS Ground service and/ or domestic mail. Should any other requested, required or international shipping methods be necessary, the postage/ shipping fee will be the responsibility of the End-User/ Customer.

1.3 CROSS REFERENCES

COMMON NAME	OFFICIAL NAME
Allen Wrench	Socket Head Screw Key
Battery Compartment	Battery Box Cover
Shipping Case	Textile Bag
Cotton Swab	Disposable Applicator
Neoprene Jack Plug	Plug Assembly
O-Ring	Gasket
Safety Screw	Electrical Dial-Knob Lock
Pattern Generator	Optical Instrument Reticle
Lens Covers	Exit Port Covers
Paddle Switch	Remote Cable Switch
Batteries	AA
Technical Manual	Operator and Field Maintenance Manual
Tape Fastener Loop	Fastener, Loop Tape
Tape Fastener Hook	Fastener, Hook Tape

1.4 LIST OF ABBREVIATIONS

C	Celsius (Centigrade)
CCW	counterclockwise
Cont'd	Continued
CW	clockwise
F	Fahrenheit
g	gram
Gen	Generation
H	Height
hr	hour
in	inch
IR	infrared
IIT	Image Intensifier Tube
kg	kilogram
L	Length
lbs	pounds
LED	Light Emitting Diode
lp/mm	line pairs per millimeter
lx	lux
m	meter
mm	millimeter
MOA	Minute of Angle
mrاد	milliradian
mrاد/lp	milliradians per line pairs
mW	milliwatt
nm	nanometer
NO	Number
NVD	Night Vision Device
oz	ounce
PMCS	Preventive Maintenance Checks and Services
RMA#	Return Merchandise Authorization number
SEQ	Sequence
SR	Service Representative
V	Volt
W	Width

DESCRIPTION AND DATA

2.1 SYSTEM DESCRIPTION

The CO-MINI consists of two primary parts: the night vision device (hereafter referred to as “NVD”), and the quick-release mount, or mount. The CO-MINI is delivered as shown in Figure 2-1: the mount (A) and Weaver rail (B) should be secured on the NVD seating rails with M4×8 screws.

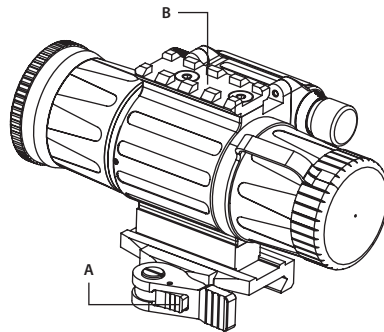

FIGURE 2-1. CO-MINI NIGHT VISION CLIP-ON DEVICE AS DELIVERED

The optical-electronic system of the NVD includes four main components: the objective and output lenses, an image intensifier tube, and the body.

The objective lens focuses available light (photons) on the photocathode of the image intensifier tube (IIT). The light energy causes electrons to be released from the cathode. After being amplified, the electron flow represents an intensified version of the original image of the scene. The electrons then strike the IIT phosphor screen, which reacts to them by glow that is visible to the human eye. The image is projected by the output lens from the IIT screen to infinity, and the resulting image is magnified when viewed through the day scope. As such, when the CO-MINI is mounted in front of the day scope, it converts the device into a night vision sight.

The automatic brightness adjustment system maintains consistent image brightness, even in changing light conditions. The manual gain control allows the operator to refine the image contrast by compensating for overly bright or extremely dark conditions.

Additionally, the CO-MINI MG version incorporates gain control, which allows the user to increase or decrease the brightness of the image to compensate for overly bright or extremely dark conditions.

The bright light protection system controls the existing ambient light through a photoreceiver, and cuts off the IIT automatically when the illumination level exceeds the limit of 100-150 lx within 10 seconds. The CO-MINI turns back on when removed from the excessively lit environment.

Automatic shut-off system automatically turns off the device when it is unused (controls are not touched) for 60 minutes. The automatic shut-off function preserves battery life should the device be inadvertently activated.

The CO-MINI is powered by a single AA or CR123A battery.

The CO-MINI uses a bi-color LED indicator to show the operator when the bright light protection system is activated, or to indicate a low battery.

The Picatinny/ Weaver mount has an adjustable lever-cam clamping device for easy, quick and reliable mounting and removal of the CO-MINI.

The CO-MINI is shown in Figure 2-2. The ITEM NO. column in Table 2-1 indicates the number used to identify items in Figure 2-2.

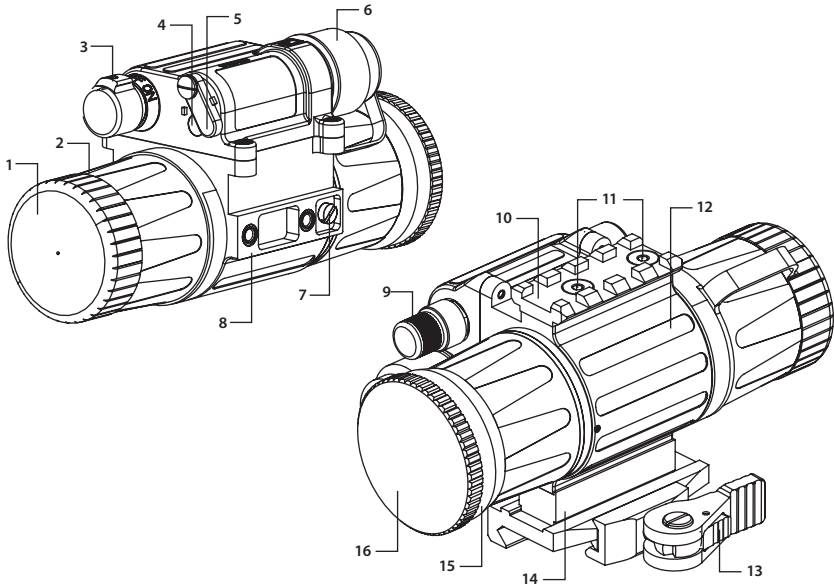

FIGURE 2-2. CO-MINI NIGHT VISION CLIP-ON DEVICE

TABLE 2-1. SYSTEM DESCRIPTION

ITEM NO.	DESCRIPTION	ITEM NO.	DESCRIPTION
1	Objective Lens Cap	9	Gain Control Knob
2	Objective Lens	10	Weaver Rail
3	Turn-Push Switch	11	M4x8 Screw
4	Photoreceiver	12	Main Body
5	Pivoted Shutter	13	Quick Release Mount
6	Battery Cap with Adapter	14	Risier
7	Purge Screw	15	Output Lens
8	Seating Rail	16	Output Lens Cap

2.2 SPECIFICATIONS

TABLE 2-2. SYSTEM DATA

ITEM	DATA
Magnification	Unity (1X)
Boresight Characteristics:	
— Accuracy	Factory aligned to 2 MOA or better
— Retention	Permanent to within 4 MOA or better
— Repeatability	Within 2 MOA
System Resolution subject to Tube Resolution:	
— 45 to 54 lp/mm	0.65 mrad/lp
— 55 to 64 lp/mm	0.53 mrad/lp
— Over 65 lp/mm	0.45 mrad/lp

TABLE 2-3. MECHANICAL DATA

ITEM	DATA
Dimensions (without Mount)	125×68×55 mm (4.9×2.7×2.2 in)
Weight* (without Mount)	0.43 kg (0.95 lbs)
Weight* (with Mount and Light Suppressor)	0.48 kg (1.06 lbs)
Height of the CO-MINI Axis above Picatinny/ Weaver Rail (with/without Riser)	38.8 / 29.3 mm (1.53 / 1.15 in)

* Without Battery

TABLE 2-4. ELECTRICAL DATA

ITEM	DATA
Battery	CR123 Lithium 3V (1), or AA Alkaline 1.5V (1), or any AA or CR123 type rechargeable batteries with voltage from 1.2V to 3.2V (1)
Battery Life (3V / 1.5V)	Up to 60 hrs / up to 40 hrs

TABLE 2-5. OPTICAL DATA

ITEM	DATA
Objective Lens Focal Length	38 mm
Objective Lens F-number	1:1.26
Focus Distance	20m to Infinity
Field of View	22°
Exit Pupil Diameter	27.5 mm

TABLE 2-6. ENVIRONMENTAL DATA

ITEM	DATA
Operating Temperature	-40 to +50°C (-40 to 122°F)
Storage Temperature	-50 to +50°C (-58 to 122°F)
Illumination Required	Natural night illumination (overcast starlight to moonlight)
Environmental Rating	Water and fog resistance (Waterproof optional)
MIL-STD-810	Complies

TABLE 2-7. XLR-IR850 ILLUMINATOR DATA

ITEM	DATA
IR Emitter Type	LED
Power	1000 mW
Peak Wavelength	850 nm
Illumination Range	Up to 1000m
Divergence	4 to 35°
Battery	Single 18650 Rechargeable Battery (3.7V)*
Battery Life at 20°C (68°F)	Up to 10 (1/4 Power); 8 (1/2 Power); 6 (3/4 Power); 2.5 (Full Power)
Overall Dimensions (with Mount)	150×48×57 mm (5.9×1.9×2.2 in)
Weight (with Mount, w/o Battery)	264 g (9.3 oz)
Operating Temperature	-20 to +50°C (-4 to 122°F)
Storage Temperature	-50 to +70°C (-58 to 158°F)
Environmental Rating	Water Resistant

* 18650 rechargeable battery and charger are included

TABLE 2-8. SCOPE MOUNTING SYSTEMS DATA

SCOPE MOUNTING SYSTEM	WEIGHT, G	OVERALL DIMENSIONS, MM	DIAMETER OF THE INSERTS, MM	CLEAR APERTURE OF DAY SCOPE LENS, MM	EXAMPLE OF THE SCOPES
Scope Mounting System 1	53	39.5×43×52.4	25,4	20; 24	Leupold 1,5-5x20 PR
			30,0		Leupold 1,5-5x20 MR/T M2; Zeiss 1,1-4x24T
Scope Mounting System 2	61	44×49×62	38,0	32; 36	Meopta Artemis 2000 4x32
			42,0		Leupold Mark 4 3-9x36; Leupold Mark 4 2,5-8x36; Kahles 4x36
Scope Mounting System 3	71	44×57.5×71	46,7	40; 42	Leupold 3,5-10x40; Leupold VX-II 3-9x40
			48,0		Zeiss 1,5-6x42; Swarovski PV-N 2,5-10x42
			48,7-49,0		Meopta Artemis 3000 3-9x42;
			49,5		Meopta Artemis 3000 4-12x40
			50,0		Schmidt&Bender 10x42
Scope Mounting System 4	82	44×65.5×79	56,0	50	Zeiss 2,5 10x50
			57,0		Schmidt&Bender 3-12x50
			58,7		Leupold 4.4-14x50; Leupold VX-III 3,5-10x50
Scope Mounting System 6	93	44×70.5×84	62,0	56	Zeiss 3-12x56; Swarovski 2,5-10x56; Kahles CSX 3-12x56

NOTE:

All data subject to change without notice.

2.3 STANDARD COMPONENTS

The CO-MINI standard components are shown in Figure 2-3 and listed in Table 2-9. The ITEM NO. column indicates the number used to identify items in Figure 2-3.

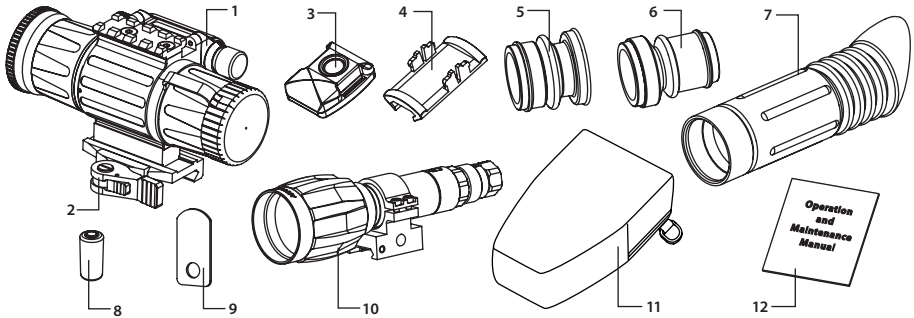

FIGURE 2-3. STANDARD COMPONENTS

TABLE 2-9. STANDARD COMPONENTS

ITEM NO.	DESCRIPTION	QUANTITY
1	CO-MINI Night Vision Clip-On Device A night vision device intended for use in conjunction with a day scope.	1
2	Single Lever-Lock Quick Release Picatinny Mount #27 A quick-release mount (QRM) used to install the CO-MINI on a Picatinny/ Weaver rail. The QRM is secured on the NVD with a riser for height alignment of the CO-MINI and day scope optical axes. The riser is furnished with two M4x18 flat head socket cap screws.	1
3	Advanced Wireless Remote Control Wireless control used to operate the CO-MINI in short-time activation mode. Ensures quick and silent CO-MINI activation/deactivation. Delivered with CR2032 (3V) battery installed.	1
4	Picatinny Adapter for Advanced Wireless Remote Control A adapter mounted to the Picatinny rail of an weapon. Allows the Advanced Wireless Remote Control to be installed on the weapon.	1
5	Light Suppressor 1 A rubber cup mounted to the CO-MINI output lens to reduce light scattering. Used when installing the CO-MINI in front of day scopes with lens housing outer diameter over the range 25.4 to 42.0 mm.	1
6	Light Suppressor 2 A rubber cup mounted to the CO-MINI output lens to reduce light scattering. Used when installing the CO-MINI in front of an ACOG 4x32 scope.	1
7	Light Suppressor for a Day Scope A rubber cup mounted to the day scope output lens to reduce light scattering when CO-MINI is used and prevent surrounding light from interfering with image on eyepiece.	1
8	Battery A single CR123A Lithium battery or AA Alkaline battery used to power the CO-MINI.	1
9	Special Wrench An instrument used for repositioning the adapter in the CO-MINI battery cap, depending on the battery being installed.	1

TABLE 2-9. CONTINUED

ITEM NO.	DESCRIPTION	QUANTITY
10	XLR-IR850 Detachable Wide Angle Adjustable X-Long-Range Infrared Illuminator A detachable LED long-range infrared illuminator with a wide, adjustable beam angle. Should be used when there is little to no ambient light. Comes fully assembled with a dedicated mount in order to be installed on a Picatinny/Weaver rail. 18650 rechargeable battery and Charger are included.	1
11	Carrying Case A protective case used for storing and carrying of the CO-MINI and its accessories.	1
12	Operation and Maintenance Manual Provides safety information, equipment description, mounting procedures, operating instructions, and preventive maintenance checks and services (including a List of Spare Parts).	1

2.4 OPTIONAL EQUIPMENT

Optional items are shown in Figure 2-4 and listed in Table 2-10.

The ITEM NO. column indicates the number used to identify items in Figure 2-4.

The PART NO. column indicates the primary number used by the manufacturer to identify an item.

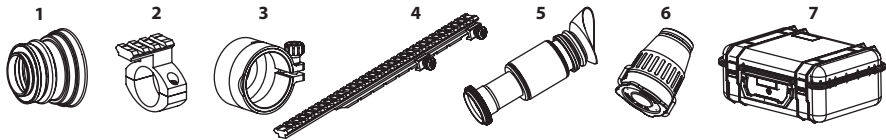

FIGURE 2-4. CO-MINI OPTIONAL EQUIPMENT

TABLE 2-10. CO-MINI OPTIONAL EQUIPMENT

ITEM NO.	DESCRIPTION	PART NO.
1	Light Suppressor 3 A rubber cup mounted to the CO-MINI output lens to reduce light scattering. Used when installing the CO-MINI in front of the day scopes having a lens housing outer diameter over the range of 47 to 50mm.	ANEC000007
2	Platform Ring #61 A mounting system with a Weaver type rail. Allows the XLR-IR850 or other additional equipment to be installed on a day scope with fitting diameter of 25.4 or 30 mm.	ANAM000032
3	Scope Mounting System 1 #40 A mounting system used to install the CO-MINI on the lenses of specified day scopes. Includes a clamp with inserts that will fit 25.4 and 30mm diameters.	ANAM000009
—	Scope Mounting System 2 #41 A mounting system used to install the CO-MINI on the lenses of specified day scopes. Includes a clamp with inserts that will fit 38 and 42mm diameters.	ANAM000010
—	Scope Mounting System 3 #42 A mounting system used to install the CO-MINI on the lenses of specified day scopes. Includes a clamp with inserts for 46.7, 48, 48.7-49, 49.5 and 50mm fitting diameters.	ANAM000011

TABLE 2-10. CONTINUED

ITEM NO.	DESCRIPTION	PART NO.
—	Scope Mounting System 4 #43 A mounting system used to install the CO-MINI on the lenses of specified day scopes. Includes a clamp with inserts for 56, 57 and 58.7mm fitting diameters.	ANAM000012
—	Scope Mounting System 6 #44 A mounting system used to install the CO-MINI on the lenses of specified day scopes. Includes a clamp with inserts for 62mm fitting diameter.	ANAM000013
4	Extended Rail Adapter #85 A mounting system used to install a day scope behind the CO-Mini on a weapon, using a short-mounting Picatinny/ Weaver rail.	ANAM000045
5	3x Magnifier Converts the CO-MINI into 3x night vision device for long-range observation.	ANLE3X0008
6	XLR-IR Afocal Doubler Doubles the distance of XLR-IR850 IR Illuminator beam. Comes complete with an thread adapter #174.	ANAF18XXLR
7	Hard Shipping/Storage Case #102 A protective case used for shipping/storage of the CO-MINI and its accessories.	ANH000004

2.5 KEY FEATURES

- Converts your day scope, sight, or binoculars into night vision-capable devices
- Mounts in front of any day scope with no re-zeroing required
- Available in a variety of high-performing Gen 2+ and Gen 3 image intensifier tube options
- Wireless remote control
- Fixed-focus objective lens effective at distances further than 20m
- Automatic or manual (CO-MINI MG only) gain control
- Powered by a single AA or CR123A battery
- Bright light cut-off system
- Bright light cut-off and low battery indicators
- Waterproof (optional)
- Filled with dry nitrogen to prevent internal fogging
- Mounts on Picatinny/ Weaver rail with a quick-release mount
- Mounts on the lenses of specified day scopes with the optional adapters
- Long-range XLR-IR850 infrared illuminator
- MIL-Standard compliant
- Limited two-year warranty

2.6 SYSTEM LIMITATIONS

The CO-MINI requires some ambient light (moonlight, starlight, etc.) to operate. Factors that can reduce natural night light and negatively affect the efficiency and operation of the CO-MINI include: rain, fog, sleet, snow, and smoke; passing cloud cover and objects that produce shadows; low-contrast environments such as snow-covered territory, sandy deserts, large bodies of water or grassy hills.

OPERATING INSTRUCTIONS

3.1 INSTALLATION AND MOUNTING

CAUTION:

To protect the image intensifier tube when the device is not in use or when it is being operated in daylight, keep the protective objective lens cap securely fitted over the lens.

3.1.1 CO-MINI BATTERY INSTALLATION

NOTE:

At operating temperatures below -20°C (-4°F), alkaline battery life will be severely reduced. Under said conditions, the use of lithium battery is recommended.

CAUTION:

Ensure that the device is off before installing a battery.

Install the battery as follows (refer to Figure 3-1):

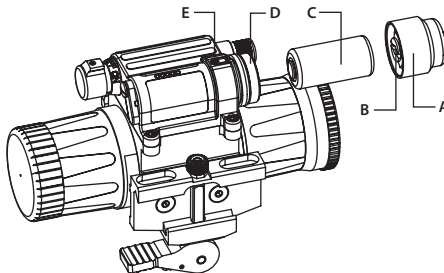

FIGURE 3-1. THE CO-MINI. BATTERY INSTALLATION

1. Unscrew the battery cap (A) and check the position of the adapter (B). See Figure 3-2 for the correct positioning of the threaded adapter, which changes depending on the battery being installed.
2. If necessary, change the adapter position in the cap. Use the special wrench.

3. Install the battery (C) into the battery compartment (D). Follow the battery symbol (E).
4. Replace the battery cap (A).

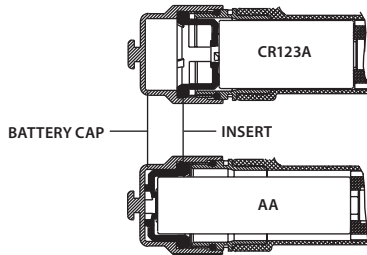

FIGURE 3-2. POSITIONS OF THE ADAPTER IN THE BATTERY CAP

3.1.2 XLR-IR850 BATTERY INSTALLATION

CAUTION:

Ensure that the IR Illuminator is off before installing the battery.

Fully charge the 18650 rechargeable battery before installing. Insert the battery into charger, aligning the polarity symbols on the battery with the polarity symbols on the charger. Never install the battery backwards.

Connect the power cord to an appropriate power source. An indicator light will flash red when a battery is charging, and will change to green when battery has been fully charged. Remove the battery promptly after charging has been completed.

Install the battery as follows (refer to Figure 3-3):

1. Unscrew the battery cap (A).
2. Install the fully charged 18650 rechargeable battery (B) into the battery compartment. Align the polarity symbols on the battery with those on the cap face.
3. Replace the battery cap (A).

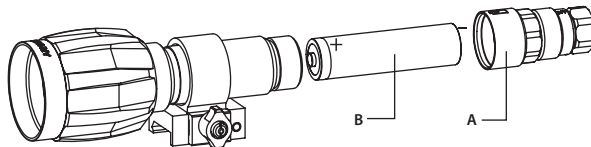

FIGURE 3-3. XLR-IR850 ILLUMINATOR. BATTERY INSTALLATION

NOTE:

The caution notice **DO NOT REMOVE IN DAYLIGHT** on the front lens cap of this universal magnifying lens is not applicable when using it on the XLR-IR850.

3.1.3 INSTALLING THE CO-MINI ONTO A PICATINNY/ WEAVER RAIL

WARNING:

When installing the equipment on a weapon, verify that the weapon is clear and that the safety is **on** before proceeding.

WARNING:

Armasight recommends using an eyecup on the eyepiece of the day scope, allowing for the eyepiece diameter and eye relief and having side paddle preferably in order to escape detection.

NOTE:

The optical axes of the CO-MINI and the day scope should align. The distance between the axes should not exceed 2mm. If the difference in the axis heights of the CO-MINI and day scope above the weapon rail exceeds 2mm, you will need to replace the day scope mounting rings or monoblock.

Install the CO-MINI on a Picatinny/ Weaver rail in front of a day scope as follows:

1. Unscrew the output lens cap.
2. Screw the light suppressor into the output lens' thread, in place of the cap.
3. Unlock the clamping device of the CO-MINI mount by pushing down on the lever holder (A, Figure 3-4) and unlocking the cam lever (B).
4. Install the CO-MINI on the Picatinny/ Weaver rail in front of the day scope. The stop (A, Figure 3-5) should slide into one of the rail's transverse slots. The light suppressor should cover the day scope's objective lens.
5. Affix the CO-MINI to the rail by locking the cam lever.
6. Verify that the clamping device (B, Figure 3-5) firmly holds the CO-MINI. If necessary, adjust the clamping device as detailed in Part 3.1.4 (Clamping Device Adjustment).

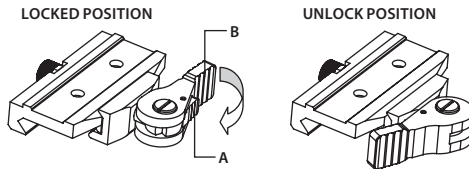

FIGURE 3-4. MOUNT. TOP VIEW

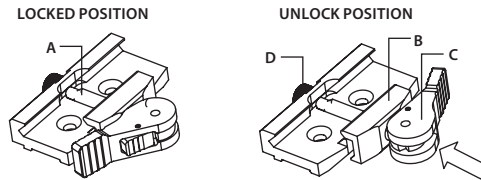

FIGURE 3-5. MOUNT. UNDERSIDE VIEW

Figure 3-6 shows the CO-MINI and a day scope installed on a Picatinny/ Weaver rail.

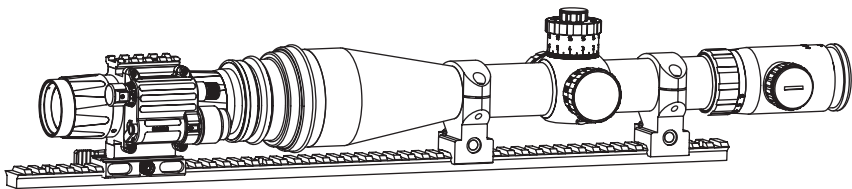

FIGURE 3-6. THE CO-MINI ON A PICATINNY RAIL IN FRONT OF A DAY SCOPE

3.1.4 CLAMPING DEVICE ADJUSTMENT

Adjust the mount clamping device as follows (refer to Figure 3-5):

1. Unlock the clamping device and remove the CO-MINI from the weapon.
2. To tighten or loosen the clamping device, push the cam (C) towards the arrow. This will cause the nut (D) to slide out of the hollow. Turn the nut (D) CW/CCW respectively, in one-two increments (see note below). Much like when the cam (C) is released, the backward-moving springs in this mechanism will cause the nut (D) to slide back into the hollow.

NOTE:

The eight-sided nut of the clamping device will **only** fit into the hollow if turned in one of the discrete positions using increments equal to $360^\circ/8$.

3. Verify that the adjusted clamping device firmly holds the CO-MINI.

3.1.5 INSTALLING THE QUICK RELEASE MOUNT

The QRM is secured on the NVD with a riser for height alignment of the CO-MINI and day scope optical axes. The riser is furnished with two M4x18 flat head socket cap screws.

The fully assembled CO-MINI with the riser is shown in Figure 3-7.

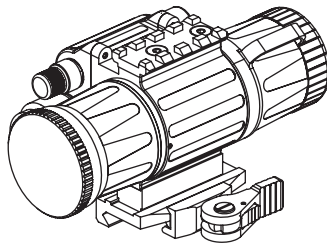

FIGURE 3-7. THE CO-MINI READY-ASSEMBLED WITH THE RISER

To replace the mount and riser from CO-MINI, do the following (refer to Figure 3-8). Using a 2.5mm Allen key, unscrew both of the M4x8 fixing screws (A) of the CO-MINI mount (B). Remove the QRM with riser (C) from the seating rail (D).

To install the QRM and rizer onto the place, do the following. Apply a small amount of thread lock to the threads. Secure the riser (C), together with the mount (B), to the seating rail (D) with two furnished M4x18 screws (A).

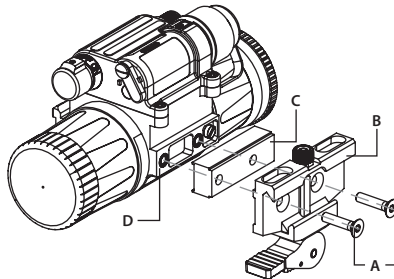

FIGURE 3-8. INSTALLING THE MOUNT WITH THE RISER

3.1.6 INSTALLING THE CO-MINI ONTO THE LENS OF A DAY SCOPE

To install the CO-MINI onto a day scope, use the optional adapters.

NOTE:

The attaching diameters of the adapters differ, and must fit with the day scope parameters specified in Table 2-8 (Scope Mounting Systems Data).

NOTE:

The CO-MINI cannot be attached to the scope if there is a focus ring attached to the objective lens' housing.

CAUTION:

The Scope Mounting Systems are **not** recommended for installing the CO-MINI on firearms that have vigorous recoil (0.308 Win or stronger).

Figure 3-9 shows the CO-MINI installed on the lens of a day scope.

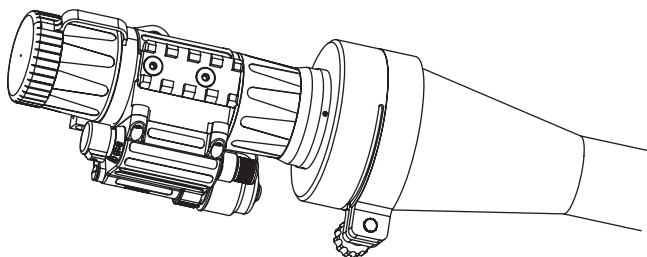

FIGURE 3-9. THE CO-MINI INSTALLED ON THE LENS OF A DAY SCOPE

To install the CO-MINI on the lens of a day scope, do the following (refer to Figure 3-10):

1. Using a 2.5mm Allen key, unscrew both M4x8 fixing screws on the CO-MINI mount. Remove the mount from the seating rail and place it, along with the screws, into the storage case.
2. Take off the output lens cap and place it into the storage case.
3. With the nut (B) loosened, position the insert (C) into the adapter's clamp (A).
4. Screw the adapter into the CO-MINI's output lens thread.
5. With the nut (B) loosened, slide the CO-MINI, with the adapter, onto the lens of the day scope as far as it will go.
6. Tighten the nut (B) with a screwdriver.

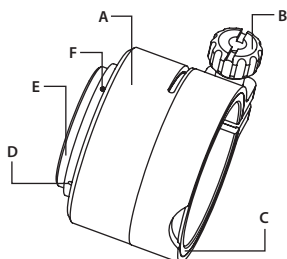

FIGURE 3-10. SCOPE MOUNTING SYSTEM

NOTE:

The second Weaver rail can be installed in place of the removed mount.

If the position of the adapter's clamping nut is undesirable, it can be adjusted by performing the following:

1. Decide on desirable position of the nut and estimate the angle through which the adapter should be turned CW (see Figure 3-11).

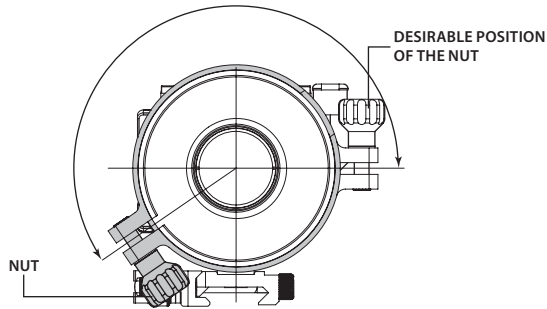

FIGURE 3-11. ESTIMATION OF THE SMS TURNING ANGLE

2. Remove the adapter from the CO-MINI.
3. Using a screwdriver, remove both screws M2×2.5 (F, see Figure 3-10) and then unscrew the ring (E).

CAUTION:

When loosening the ring (E), only utilize the two auxiliary, non-threaded holes (D). Avoid using the threaded ones.

4. Using a turning machine, cut the inside face of the ring (E). The value of cutting (in millimeters) is equal to the value of the turning angle (in angular degrees) divided by 360°.
5. With the cut end directed inwards, screw the ring (E) into the adapter's body and tighten it.
6. Apply a small amount of thread lock to the threads. Affix the ring (E) with two M2×2.5 screws (F).

3.1.7 FASTENING A WIRELESS REMOTE CONTROL UNIT TO WEAPON

Using Velcro tape (A, Figure 3-12), fasten the remote control unit (B) to the weapon in an easily accessible place (e.g., on the front of the rifle stock) on the side of the CO-MINI's wired cover preferably.

If your rifle has a Picatinny or Weaver rail on the forend you can use the Picatinny Adapter for Advanced Wireless Remote (C). Install adapter on the rail. Insert the remote control unit in the adapter.

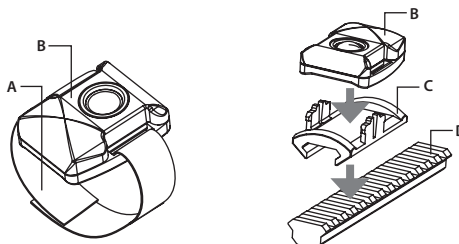

FIGURE 3-12. ADVANCED WIRELESS REMOTE CONTROL

3.1.8 INSTALLING THE IR ILLUMINATOR

Armasight long range IR illuminators are delivered with a dedicated mount, to be installed on the Picatinny/Weaver rail.

To mount an IR illuminator, do the following (refer to Figure 3-13):

1. With the nut (A) loosened, install the mount (B) on the rail so that the stop (C) slides into one of the transverse slots of the rail.
2. Tighten the nut (A).

NOTE:

The mount clamp (D) has a spherical hinge that allows the IR illuminator to be aligned with the field of view of the CO-MINI for maximum effectiveness.

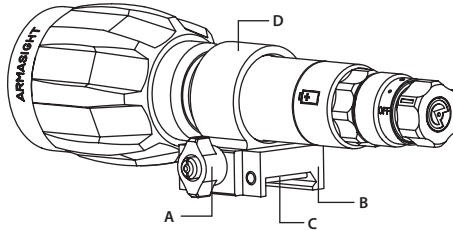

FIGURE 3-13. XLR-IR850 IR ILLUMINATOR

The XLR-IR850 can be used as hand-held long-range IR illuminator with optional Afocal Doubler. Attach the magnifying lens to the XLR-IR850 as follows (refer to Figure 3-14):

1. Screw the Afocal Doubler (A) into the threading adapter (B).
2. Screw the Afocal Doubler with adapter into the threading of the XLR-IR850 objective lens (C) housing. Be careful not to over-tighten the lens.

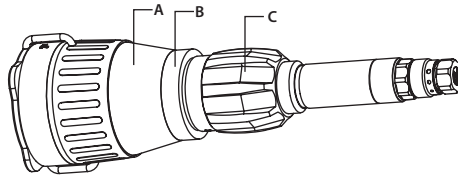

FIGURE 3-14. XLR-IR850 ILLUMINATOR WITH AFOCAL DOUBLER

3.1.9 INSTALLING THE 3X MAGNIFIER

Figure 3-15 shows the CO-MINI with installed 3x magnifier.

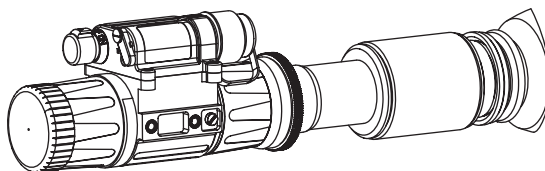

FIGURE 3-15. THE CO-MINI WITH A 3X MAGNIFIER

To install the 3x magnifier on the CO-MINI, do the following:

1. Take off the output lens cap and place it into the storage case.
2. Screw the 3x magnifier into the CO-MINI's output lens thread.

3.1.10 INSTALLING THE LIGHT SUPPRESSOR FOR A DAY SCOPE

The Light Suppressor for a Day Scope (A) slides over the eyepiece of your daytime scope (B). The suppressor can be used with scopes that have 40..43mm eyepiece diameter and 100..120 mm eye relief.

The suppressor can be adjusted for the eye relief of your scope by cutting the rubber at the desired distance (C).

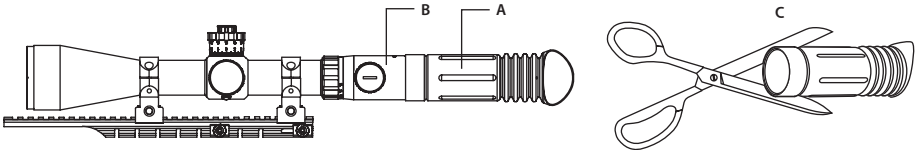

FIGURE 3-16. LIGHT SUPPRESSOR FOR A DAY SCOPE

3.2 CONTROLS AND INDICATORS

CAUTION:

DO NOT force the equipment controls past their stopping points.

3.2.1 CO-MINI CONTROLS AND INDICATORS

The CO-MINI controls are shown in Figure 3-17.

The CO-MINI controls and indicators are defined in Table 3-1. The ITEM NO. column indicates the number used to identify items in Figure 3-17.

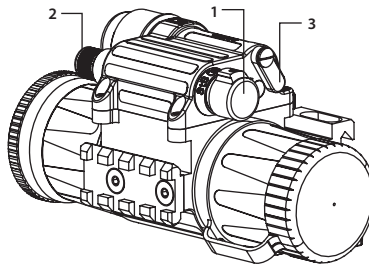

FIGURE 3-17. CO-MINI CONTROLS

TABLE 3-1. CO-MINI CONTROLS AND INDICATORS

ITEM NO.	CONTROL/INDICATOR	FUNCTION
1	Turn-Push Switch	<p>Activates the CO-MINI when turned CW from OFF to ON. The switch must be pushed to turn the device on.</p> <p>Activates the standby mode when turned CCW from OFF to STB. The switch must be pushed to switch to STB.</p> <p>Deactivates the CO-MINI when turned from ON/ STB to OFF.</p>
2	Gain Control Knob*	Adjusts the brightness of the image.
—	Remote Control Button	Activates/ deactivates the CO-MINI in standby when pressed/released.
3	Pivoted Shutter	Closes/ opens the photoreceiver when placed in the highest/lowest position.
—	Built-in Bi-Color LED Indicator	<p>PERMANENT YELLOW GLOW in the viewing area indicates excessive light conditions. After 10 seconds of exposure to excess light, the image intensifier tube will be cut off. The CO-MINI will turn back on when moved away from the excessive light.</p> <p>A FLASHING RED LIGHT in the viewing area indicates a low battery. The LED will flash three times every 3 minutes.</p>

*For CO-Mini MG version only.

3.2.2 IR ILLUMINATOR CONTROLS

The controls of the optional IR illuminators are shown in Figure 3-18 and defined in Table 3-2. The ITEM NO. column indicates the number used to identify items in Figure 3-18.

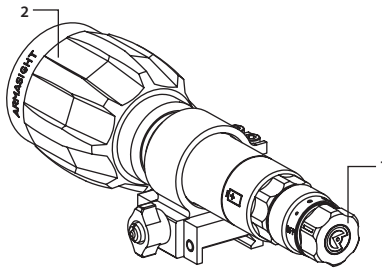

FIGURE 3-18. IR ILLUMINATOR CONTROLS

TABLE 3-2. IR ILLUMINATOR CONTROLS

ITEM NO.	FUNCTION	DESCRIPTION
1	POWER SWITCH	Switches the IR illuminator on/off and adjusts for radiated power. Four ON positions are located between the two OFF positions, and are each marked with a different-sized spot. The larger the spot, the greater the radiated power.
2	LENS FOCUS	Adjusts for IR beam divergence. Adjustment range is covered within approximately one turn of the lens.

3.3 OPERATING PROCEDURES

3.3.1 OPERATING THE CO-MINI

Operating procedures should be performed in dark or nighttime conditions only.

CAUTION:

Use of the CO-MINI in brightly lit conditions may damage the image intensifier tube.

1. Verify that the battery is installed as required.
2. Perform a visual estimation of the illumination level in the viewing area, using the reference data presented in Appendix A. You can begin operating the CO-MINI if the illumination level is less than 1 lx.
3. Remove the objective lens cap and place it over the lens' housing.

CAUTION:

Before removing the objective lens cap, verify that the photoreceiver is open.

4. Verify that there are no bright light sources in the CO-MINI's field of view. Turn the device on. After a slight delay, a green glow will appear in the day scope's output lens.

CAUTION:

Avoid exposing the device to bright light sources such as firelight, headlights, searchlights, etc., as these can damage the CO-MINI.

5. To operate the CO-MINI in short-time activation mode, put the device in standby mode. To activate the CO-MINI, press and hold the remote control button. Release the remote control button to deactivate the CO-MINI.
6. Observe the scene. Adjust the image contrast by rotating the gain control knob (CO-MINI MG only).
7. If the day scope includes a focusing ring (i.e., parallax adjustment knob), adjust the focus for a parallax-free image.
8. Turn on the day scope's reticle illumination and adjust the reticle brightness.

CAUTION:

Do not leave the CO-MINI activated if it is not being used.

NOTE:

If the automatic shut-off system automatically turns off the device when it is used you need turn the operation switch to OFF position and then back to ON position for continuing the operation.

3.3.2 OPERATING THE IR ILLUMINATOR

Use an IR illuminator when there is little to no ambient light.

CAUTION:

The IR illuminator infrared light will be invisible to the naked eye. The light can, however, be detected by other night vision devices.

CAUTION:

DO NOT leave the IR illuminator activated in the ON position if it is not being used.

Operate the IR illuminator as follows:

1. Turn on the IR illuminator by rotating the power switch (A) from OFF position.
2. To change the power level, turn the power switch to one of the spots between the two OFF positions.
3. To adjust IR beam divergence, turn the objective lens of IR illuminator (B).
4. To adjust the IR spot position in the field of view, loosen the two clamp screws (C) and tilt the IR illuminator as required in the spherical clamp hinge. Tighten the screws using a 2.5 mm hex key.

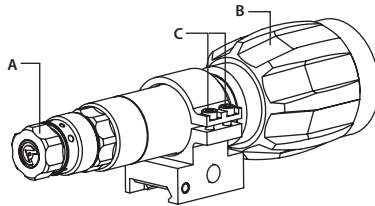

FIGURE 3-19. IR ILLUMINATOR ADJUSTMENT

3.3.3 OPERATING IN CHANGING LIGHT CONDITIONS

If a mission must be carried out in changing light conditions, you can deactivate the bright light protection system of the CO-MINI. To shut down the protection system, close the photoreceiver by flipping up the pivoted shutter.

CAUTION:

After your mission is complete, open the photoreceiver by flipping the pivoted shutter down.

3.3.4 SHUT-DOWN

Shut-down the CO-MINI as follows:

1. Turn off the device. The green glow will disappear.
2. Place the cap over the objective lens.
3. Remove the CO-MINI from the weapon/day scope lens.
4. Remove the light suppressor from the output lens.
5. Screw the cap into the output lens thread.
6. Remove the XLR-IR850 from the CO-MINI.
7. Remove the batteries.

CAUTION:

Do not store the equipment with the battery still in it.

CAUTION:

Remove the light suppressor from the CO-MINI to avoid deformation or damage.

8. Ensure that the CO-MINI and any accessories are clean and dry before placing them into the storage case.
9. Place the CO-MINI and any accessories into the appropriate locations in the storage case and close the cover.

PREVENTIVE MAINTENANCE AND TROUBLESHOOTING

4.1 PREVENTIVE MAINTENANCE CHECKS AND SERVICES (PMCS)

Table 4-1: Preventive Maintenance Checks and Services has been provided so that you can keep your equipment operable and in good condition.

Perform all functional tests in the order listed in Table 4-1.

Operating Procedures are detailed in Chapter 3.

Always observe any CAUTIONS that appear in the table.

Explanation of Table Entries:

SEQ NO. column. Sequence numbers are for reference and appear in the order required to perform checks and services.

LOCATION OF ITEM TO CHECK/ SERVICE column. Indicates the location and the item to be checked or serviced.

PROCEDURE column. Details the checking/ servicing procedure.

NOT FULLY MISSION CAPABLE IF... column. Indicates what faults will prevent your equipment from operating successfully.

TABLE 4-1. PREVENTIVE MAINTENANCE CHECKS AND SERVICES

SEQ. NO.	LOCATION OF ITEM TO CHECK/ SERVICE	PROCEDURE	NOT FULLY MISSION CAPABLE IF...
PRE-OPERATIONAL CHECKS			
1	Completeness	Inventory items by comparing them with the data specified in this manual.	Items are missing.
2	Body	Inspect for cracks or damage. Scratches and gouges are OK if operation is not affected. Inspect for missing parts (screws, knobs).	Cracked or damaged. Screw or knob is missing.
3	Objective Lens Cap	Inspect for cuts, tears and dirt. Clean as required.	Cap is torn or cut.
4	Output Lens Cap	Inspect for dirt. Check ease of installation and removal. Clean as required.	Cap is difficult to remove.
5	Battery Compartment/ Cap with Adapter	Check to make sure the adapter is present. Check for corrosion, cap damage or retainer breaks. Check O-ring for cuts or damage.	Retainer is broken. Cap, O-ring or battery adapter is damaged or missing.
6	Switch	Check for operation (without battery).	Switch is inoperative.

TABLE 4-1. CONTINUED

SEQ. NO.	LOCATION OF ITEM TO CHECK/ SERVICE	PROCEDURE	NOT FULLY MISSION CAPABLE IF...
7	Lenses	Inspect for cleanliness, scratches, chips or cracks. Clean as required.	Chipped or cracked. Scratches hinder vision through the CO-MINI.
8	Photoreceiver	Inspect for cleanliness, scratches. Clean as required.	Photoreceiver is damaged.
9	Remote Control Unit	Check for damage. Check Velcro tape for wear.	Damaged. Unit or tape is missing.
10	Light Suppressors	Inspect for cuts or tears. Check ease of installation and removal.	Light suppressor is torn or cut.
11	Mount	Inspect for damage or corrosion, and for missing parts. Check for proper operation.	Damaged. Some parts are missing. Clamping device is inoperative.
12	XLR-IR850 Body, Mount	Inspect for damage and missing parts.	Damaged. Missing parts.
13	XLR-IR850 Battery Cap, Power Switch	Check O-ring for damage. Check for proper operation.	O-ring is damaged or missing. Switch is inoperative.
14	XLR-IR850 Lens	Inspect for cleanliness, scratches, chips or cracks. Clean as required. Check to ensure there is free rotation through the full range of travel (one turn).	Lens is chipped or cracked. Lens sticks or is too loose when turned.
15	Scope Mounting System	Inspect for damage and missing parts.	Damaged. Missing parts.
16	Optional Extended Rail Adapter	Inspect for damage and missing parts. Check clamping devices for proper operation.	Damaged. Missing some parts. Clamping devices inoperative.

OPERATIONAL CHECKS

CAUTION:

The objective lens cap has an axial pinhole, which allows operational testing of the CO-MINI in daylight. Activate the CO-MINI in daylight with the objective lens cap on or in dark conditions. DO NOT forget to open the photoreceiver after finishing operational checks.

NOTE:

Daylight checks are described below.

17	Turn-Push Switch	Insert the battery. Remove the output lens cap. Close the photoreceiver by flipping up the pivotal shutter. Push and turn the switch to ON. Look for green glow (after a slight delay) in viewing area. Open the photoreceiver by flipping the pivotal shutter down. Look through the output lens and wait about 10 seconds for the green glow to disappear.	No green glow. Green glow is present, yellow glow is absent.
18	Remote Control	Close the photoreceiver. Push and turn the switch to STB. Press and hold the remote control button. Look for the green glow in the output lens. Release the button. Turn the switch to OFF.	Green glow is absent.
19	Gain Control Knob (CO-Mini MG only)	Push and turn the switch to ON. Rotate the gain control knob to ensure it adjusts the screen's brightness.	Knob does not adjust the screen's brightness.
20	Viewed Image	Inspect for any operational defects (refer to Section 4.3: Inspection Criteria for Proper Image Intensifier Operation).	Shading, edge glow, flashing, flickering, and intermittent operation, or excessive cosmetic defects are found.
21	XLR-IR850 IR Illuminator	Insert the battery. Mount the XLR-IR850 onto the CO-MINI. Turn the XLR-IR850 on. Direct the radiated beam at a wall from a distance of about 5m. Look through the CO-MINI. A square of light should appear on the wall.	No light appears on the wall.

POST-CHECK PROCEDURES

22		Turn off the XLR-IR850 and CO-MINI. Screw the protective cap into the CO-MINI output lens thread. Remove the batteries. Return the CO-MINI and all accessories to the storage case.	
----	--	---	--

4.2 OPERATOR TROUBLESHOOTING

The purpose of troubleshooting is to identify the most commonly occurring equipment malfunctions, their probable causes, and the corrective actions required to fix them.

Table 4-2 lists the common malfunctions that may occur during the operation or maintenance of the CO-MINI. Perform the tests, inspections, and corrective actions in the order listed in the table.

This table cannot list all of the malfunctions that may occur with your CO-MINI, or all of the tests and corrective actions that may be necessary. If you experience an equipment malfunction that is not listed, or is not fixed by the corrective actions listed in the table, please contact Armasight's Customer Service center.

TABLE 4-2. OPERATOR TROUBLESHOOTING

MALFUNCTION	PROBABLE CAUSE/ TEST/INSPECTION	CORRECTIVE ACTION
CO-MINI fails to activate.	Battery is missing or improperly installed.	Insert battery or install correctly.
	Battery is dead.	Replace the battery.
	Battery surfaces or contacts are dirty or corroded.	Clean the contact surfaces with a pencil eraser and/or alcohol and cotton swabs.
	Remote control unit is damaged.	Please contact Customer Support.
	Remote control battery is dead.	Replace the battery as per Part 4.4.3.
	Defective image intensifier.	Please contact Customer Support.
Poor image quality.	Objective and output lenses are dirty.	Thoroughly clean the surfaces of each lens.
	Damaged optical components.	Please contact Customer Support.
LED indicator fails to activate.	Visual inspection.	Please contact Customer Support.
CO-MINI affects boresight after installation or during the firing.	Factory alignment is broken.	Please contact Customer Support.
Hindered rotation of the battery cap.	Dirty cap thread.	Clean the thread.
	Damaged cap thread.	Please contact Customer Support.
Battery adapter difficult to remove.	Check for damaged battery adapter and battery cap.	If damaged please contact Customer Support.
Light visible around light suppressor.	Incorrect position of the CO-MINI relative to the day scope.	Align the CO-MINI position relative to the day scope.
	Check the light suppressor resilience.	If light suppressor is defective please contact Customer Support.
XLR-IR850 fails to activate.	Battery is missing or improperly installed.	Insert battery or install it correctly.
	Battery is dead.	Replace the battery.
	XLR-IR850 damaged.	Please contact Customer Support.

4.3 INSPECTION CRITERIA FOR PROPER IMAGE INTENSIFIER TUBE OPERATION

4.3.1 OPERATIONAL DEFECTS

Operational defects relate to the reliability of the intensifier, and are an indication of instability. If identified, the user will need to return the CO-MINI immediately. Operational defects include shading, edge glow, flashing, flickering, and intermittent operation.

A. Shading

If shading is persistent, you will not be able to see a fully circular image (Figure 4-1). Shading is a very dark, high-contrast area with a distinct line of demarcation present, and you cannot see an image through it. Shading always begins on the edge and will eventually migrate inward until it spans across the entire image area. If you notice shading with your device, please contact Customer Support.

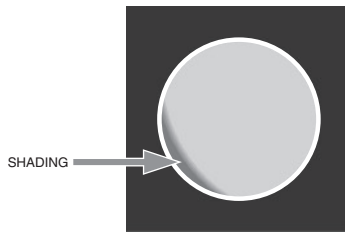

FIGURE 4-1. SHADING

NOTE:

Verify that any shading is not the result of improper eye-relief adjustment.

B. Edge Glow

Edge glow is a bright area (it sometimes appears to be coloring) in the outer portion of the viewing area (see Figure 4-2). To check for edge glow, block out all light from the device by cupping a hand over the lens. If the image intensifier tube is displaying edge glow, the bright area will still show up; if edge glow occurs please contact Customer Support.

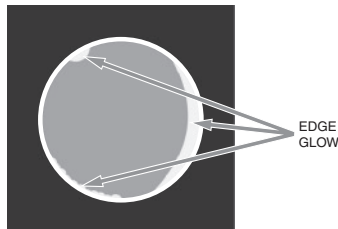

FIGURE 4-2. EDGE GLOW

C. Flashing, Flickering, or Intermittent Operation

The image may appear to flicker or flash. If there is more than a single flicker, check for a loose battery adapter or a weak battery. If flickering continues, please contact Customer Support.

4.3.2 COSMETIC BLEMISHES

Cosmetic blemishes are usually the result of manufacturing imperfections. They do not affect the reliability of the image intensifier tube, and are not normally a cause for returning the CO-MINI. However, some types of cosmetic blemishes can worsen over time and interfere with the user's ability to properly operate the device during missions. If you believe a cosmetic blemish is cause for returning the device, record the specific nature of the problem on the maintenance forms and use the clock method to identify the position of the blemish and approximate distance from the center (e.g., 5:00 toward the outside, 2:30 near the center, or 1:00 midway).

The following are examples of cosmetic blemishes:

A. Bright Spots

A bright spot is a small, non-uniform bright area that may flicker or appear constant (Figure 4-3).

Not all bright spots make the CO-MINI returnable. Cup your hand over the lens to block out all light. If the bright spot remains, please contact Customer Support.

Bright spots usually go away when all light is blocked out. Verify that any bright spots are not simply the result of bright light in the area you are observing. Bright spots are acceptable if they do not interfere with the user's ability to view the scene or perform missions.

B. Emission points

Emission points are steady or fluctuating pinpoints of bright light in the image area that do not go away when all external light is blocked from the objective lens (Figure 4-3). The position of an emission point within the image area does not move. Not all emission points are cause to return the CO-MINI. Verify that emission points are not simply light sources present in the scene you are observing. Emission points are acceptable if they do not interfere with the user's ability to perform missions.

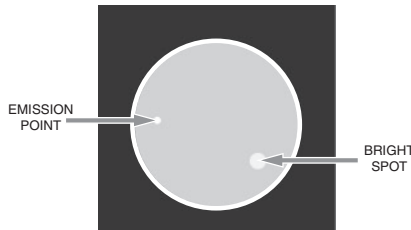

FIGURE 4-3. EMISSION POINTS AND BRIGHT SPOTS

C. Black Spots

Black spots are cosmetic blemishes in the image intensifier or debris between the lenses. Black spots are acceptable as long as they do not interfere with the user's ability to observe the scene. No action is required if this condition is present, unless the spots interfere with the operator's ability to perform missions.

D. Fixed-pattern Noise

Fixed-pattern noise is usually a cosmetic blemish characterized by a faint hexagonal (honeycomb) pattern that appears throughout the viewing area. This typically occurs in excessively lit environments or when viewing very bright lights (Figure 4-4). This pattern can be seen in every image intensifier if the level of light is high enough. This condition is acceptable as long as the pattern does not interfere with the user's ability to view an image or their ability to perform missions.

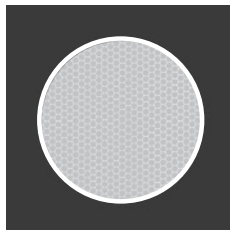

FIGURE 4-4. FIXED-PATTERN NOISE

E. Chicken Wire

Chicken Wire is an irregular pattern of dark thin lines that can appear in the field of view, either throughout the image area or in sections of the image area (Figure 4-5). In the worst-case scenario, these lines will form hexagonal or square, wave-shaped lines. No action is required if this condition is present, unless it interferes with the user's ability to view an image or their ability to perform missions.



FIGURE 4-5. CHICKEN WIRE

4.4 MAINTENANCE

4.4.1 GENERAL

The section regarding CO-MINI operator maintenance consists of operational tests, inspections for unit serviceability, cleaning and mounting procedures, troubleshooting, and replacement instructions for a limited number of parts. Maintenance instructions covered elsewhere in this manual (PMCS, troubleshooting, etc.) are not repeated in this section.

CAUTION:

The CO-MINI is a precision electro-optical instrument, and must be handled carefully at all times to prevent damage to body and mechanisms.

4.4.2 CLEANING PROCEDURES

CAUTION:

Thoroughly dry each item before placing them into the storage case.

Clean the CO-MINI and XLR-IR850 as follows:

1. Gently brush off any dirt from the device's body using a clean, soft cloth.
2. Moisten the cloth with fresh water and gently wipe external surfaces (except for glass surfaces).
3. Dry any wet surfaces (except for glass surfaces) with another clean, soft, dry cloth.
4. Using a lens brush, carefully remove all loose dirt from the glass surfaces.
5. Slightly dampen a cotton swab with ethanol. Gently and slowly wipe the lenses (including the photoreceiver). Without touching the lens holders, clean the glass surfaces in circular movements, beginning in the center and moving out towards the edge. Change the cotton swab after each circular stroke. Repeat until the glass surfaces are clean.
6. Clean the battery surfaces and contacts with a pencil eraser and/ or alcohol-dampened cotton swabs.

Clean optional equipment with a soft brush (cloth), soap, and water as required.

4.4.3 BATTERY REMOVAL AND REPLACEMENT

Refer to Parts 3.1.1 and 3.1.2 for the CO-MINI and XLR-IR850 battery installation procedure, respectively.

Replace the remote control battery as follows:

1. Using a screwdriver, unscrew the four screws (A, Figure 4-6) that affix the cover to the bottom of the unit. Remove the cover.
2. Replace the battery with new one (CR2032, 3V). Stack the battery in its place under the leaf contact spring with the minus contacts directed towards the electric board, as the minus sign etched on the board indicates.
3. Replace the cover and retighten the screws (A).

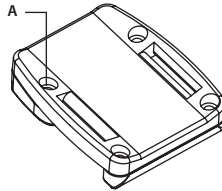

FIGURE 4-6. ADVANCED WIRELESS REMOTE CONTROL BATTERY INSTALLATION

4.5 RETURN INSTRUCTIONS

For service, repair or replacement, please email service@armasight.com

To assist the Service Representative (SR) with determining whether or not an item is repairable, please provide the following information:

1. Serial Number of the defective item.
2. Thorough description of the malfunction, defect or damage.
3. An explanation of how the malfunction, defect or damage occurred, if known.

If the SR determines that the item is under warranty or should be returned for repair, a Return Material Authorization number (RMA#) will be provided. RMA can be obtained via e-mail to service@armasight.com or via phone by calling Armasight Customer Service at (888)959-2259 Ext. 2 or via fax (888)959-2260.

When returning the CO-MINI for service or repair, the following procedures should be done to prevent any additional damage:

1. Verify that the CO-MINI is free of all contaminants, such as dirt or any other foreign material.
2. Remove the battery.
3. Place the cap over the objective lens.
4. Screw the cap into the output lens thread.
5. Place the CO-MINI and its accessories into the shipping case.
6. Place the CO-MINI and a copy of the test report or detailed description of the failure in a suitable packing/ shipping container. Mark the package with the RMA#. Ship using a fast, traceable service. Shipping must be prepaid by the Customer.

A. ESTIMATION OF AMBIENT ILLUMINATION LEVEL

Table A-1 lists some common natural light conditions and their corresponding representative illumination values.

TABLE A-1. STANDARD NATURAL LIGHT CONDITIONS AND ILLUMINATION VALUES

STANDARD NATURAL LIGHT CONDITIONS	ILLUMINATION VALUE, LUX
Quarter moon	0.05
Full moon	0.30
Late twilight sky	1.00
Twilight sky	10.00
Overcast sky in the daytime	500.00

B. LIST OF SPARE PARTS

The parts authorized in the below list of spare parts are required for operator maintenance. This list includes parts that must be removed in order to replace authorized parts.

The ITEM NO. column indicates the number used to identify items in Figure B-1.

The PART NO. column indicates the primary number used by the manufacturer to identify an item; this number controls the design and characteristics of the item by means of its engineering, specifications, standards, and inspection requirements.

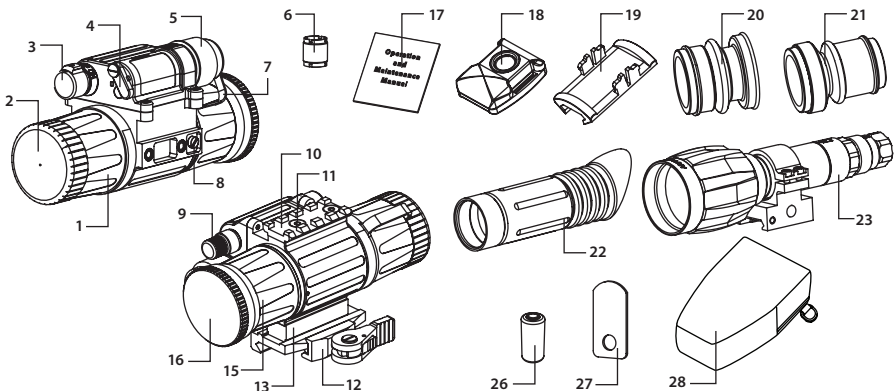

FIGURE B-1. CO-MINI SPARE PARTS

TABLE B-1. CO-MINI LIST OF SPARE PARTS

ITEM NO.	DESCRIPTION	PART NO.
1	Objective Lens Assembly	COMNOBL
2	Objective Lens Cap	COMNOBLC
3	Turn-Push Switch	COMNTS
4	Pivoted Shutter	COMNPS
5	Battery Cap	COMNBC
6	Battery Adapter	COMNBA
7	Battery Cap Retainer	COMNBCR
8	Purge Screw	COMNPSC
9	Gain Control Knob (CO-MINI MG only)	COMNGCK
10	Weaver Rail	COMNWR
11	M4×8 Screw	ALT
12	Single Lever-Lock Quick Releas mount Mount	COMNQRM
13	Riser	COMNRSR
14	M4×18 flat head socket cap screws (not shown)	ALT
15	Output Lens Assembly	COMNOLA
16	Output Lens Cap	COMNOLC
17	Operation and Maintenance Manual	COMNOMM
18	Advanced Wireless Remote Control (AWREC)	ANWR000001
19	Picatinny Adapter for AWREC	ANRA000002
20	Light Suppressor 1	ANEC000005
21	Light Suppressor 2	ANEC000006
22	Light Suppressor for a Day Scope	ANEC000011
23	XLR-IR850 Illuminator	IAIR850IR000001
24	18650 Rechargeable Battery (not shown)	ALT
25	Charger for 18650 Rechargeable Battery (not shown)	ALT
26	CR123A Battery	ALT
27	Special Wrench	COMNSW
28	Carrying Case	COMNCC
29	CR2016 Battery for AWREC (not shown)	ALT

C. PRODUCT WARRANTY REGISTRATION CARD

In order to validate the warranty on your product, Armasight must receive a completed Product Warranty Registration Card for each unit, or the user must complete warranty registration on our website (www.armsight.com). Please complete the included form and immediately mail it to our Service Center:

Armasight Inc.
815 Dubuque Avenue
South San Francisco
CA 94080
USA

ARMASIGHT PRODUCT WARRANTY REGISTRATION CARD

PRODUCT INFORMATION

Product Name _____ Purchased From _____
Purchase Date _____ Product Serial # _____

CUSTOMER INFORMATION

Name _____
Address _____
City _____ Country _____ Zip _____
Day Phone # _____ Home Phone # _____
E-mail address _____

.....
Customer Signature Required

ALPHABETICAL INDEX

A			
ABBREVIATIONS	10		
B			
BATTERY INSTALLATION	18		
BLACK SPOTS	33		
BRIGHT SPOTS	33		
C			
CAUTIONS	2		
CELL LIFE	13		
CHICKEN WIRE	33		
CLEANING	34		
COSMETIC BLEMISHES	32		
E			
EDGE GLOW	32		
EMISSION POINTS	33		
F			
FIXED-PATTERN NOISE	33		
FLASHING, FLICKERING, OR INTERMITTENT OPERATION	32		
G			
GENERAL INFORMATION	7		
H			
HEIGHT	13		
I			
IR ILLUMINATOR	14, 19, 26		
L			
LENGTH		13	
M			
MAINTENANCE		29	
MOUNTING		18	
O			
OPERATING INSTRUCTIONS		18	
OPERATIONAL DEFECTS		31	
OPERATOR TROUBLESHOOTING		31	
P			
PMCS		29	
S			
SAFETY SUMMARY		3	
SHADING		32	
SHUT-DOWN		28	
SPARE PARTS		36	
SYSTEM DESCRIPTION		11	
T			
TURN-PUSH SWITCH		12, 26, 30	
W			
WARRANTY INFORMATION		8	
WEIGHT		13	
WIDTH		13	



Armasight Inc.

815 Dubuque Avenue
South San Francisco
CA 94080, USA

Phone: (888)959-2259

Fax: (888)959-2260

Intl Phone/Fax: (650)492-7755

info@armasight.com



WARNING!

This product contains natural rubber latex which may cause allergic reactions! The FDA has noted an increase in the number of reported deaths that are associated with an apparent sensitivity to natural latex proteins. If you are allergic to latex, it is a good idea to learn which products contain it and strictly avoid exposure to those products.

www.armasight.com